

THE NEW D-500 MK2

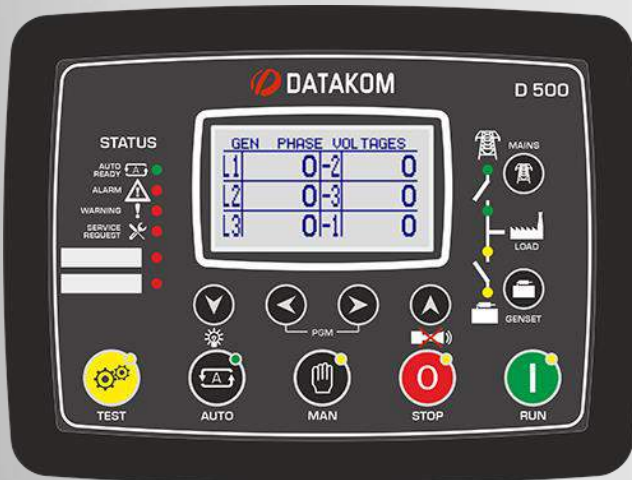

- BOTH AMF AND SYNCHRONIZING
- SAME UNIT FOR ALL FUNCTIONS
- INTERNET BASED
- MULTI-PROTOCOL
- FLEXIBLE WITH PLUG-IN MODULES
- AUTO LEARNING

FEATURES

- Diesel and gas genset support
- 400Hz operation support
- 400 event logs, full snapshot
- All parameters front panel editable
- 3 level configuration password
- 128x64 graphical LCD display
- Downloadable languages
- Waveform display of V & I
- Harmonic analysis of V & I
- Synchroscope & check synch
- Allows closed transfers
- 16Amp MCB & GCB outputs
- 8 configurable digital inputs
- Inputs expandable to 40
- 8 configurable digital outputs
- Outputs expandable to 40
- 7 configurable analog inputs
- Both CANBUS-J1939 & MPU
- 3 configurable service alarms
- Multiple topologies
- 6xCT, true mains metering
- Supports up to 48 gensets
- Automatic learning/self adjust
- Direct governor & AVR control
- Voltage and phase matching
- kW & kVAr load sharing
- True soft transfer in both ways
- PLC functions
- Peak Lopping / peak shaving
- Mains de-coupling protection
- R.O.C.O.F protection
- Vector shift protection
- Reverse power protection
- Over/under freq. Protection
- Over/under voltage protection
- Smart load management
- Smart genset sequencing
- Run/stop priority support
- Equal aging of gensets
- Base load (power export)
- Unmanaged distributed power export support
- AVR & GOV droop support
- Dead bus sensing
- Multiple automatic exerciser
- Weekly operation schedule
- Dual mutual standby with equal aging of gensets
- Manual "speed fine adjust" on selected ECUs
- Automatic fuel pump control
- Disable protections feature
- Excess power protection
- Reverse power protection
- Overload IDMT protection
- Load shedding, dummy load
- Multiple load management
- Current unbalance protection
- Voltage unbalance protection
- Fuel filling & fuel theft alarms
- Contactor & MCB drive
- Battery back-up real time clock
- Idle speed control
- Battery charge run enabled
- Combat mode support
- Multiple nominal conditions
- 4 quadrant genset power counters
- Mains power counters
- Fuel filling counter
- Fuel consumption counter
- Modem & ethernet diagnostics
- Configurable through USB, RS-485, Ethernet and GPRS
- Free configuration program
- Allows SMS controls
- Ready for central monitoring ethernet & GPRS
- Mobile genset support
- Automatic GSM geo-location
- GPS connectivity (USB&RS232)
- Dynamic DNS support
- Easy USB firmware upgrade
- IP65 rating with standard gasket



RoHS

EAC

CE US

CE

 DATAKOM

PLUG-IN MODULES

- 2G GSM Modem
- 3G-2G GSM Modem
- 4G-3G-2G (CAT-4) Modem
- NB/IOT, CAT-M1, 2G Modem
- Wi-Fi (802.11 b/g/n)
- Ethernet 100 Mbps
- USB Host
- RS-232 (isolated)
- RS-485 (isolated)
- Synchro/LoadShare Module
- 3x AC Current Inputs
- 3x Analog Inputs
- DC Voltage and Current Inputs
- Tilt Detector



Backpanel view

FUNCTIONALITIES

- Multi genset synch & load share
- Mains synchronization
- Single genset parallel with mains
- AMF unit (uninterrupted transfer)
- ATS unit (uninterrupted transfer)
- Remote start controller
- Manual start controller
- Engine controller
- Remote display panel

COMMUNICATIONS

- Central Monitoring
- Embedded Web Server
- USB
- GPS (geo-location)
- SMS
- E-mail
- Modbus
- Modbus TCP/IP
- SNMP 1.0 with trap
- HTML
- UDP
- SNTTP

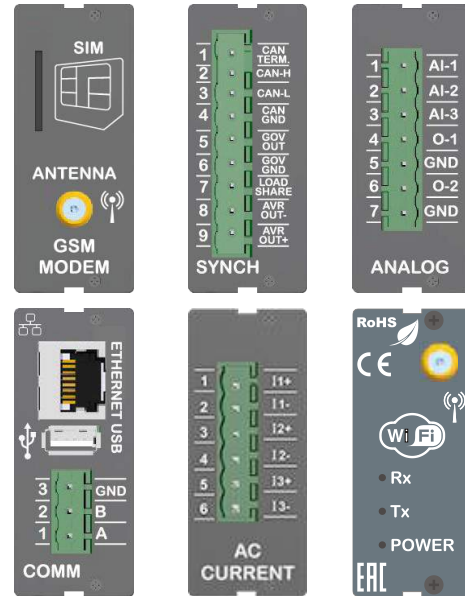

Plug-in modules

MULTI GENSET SYNCHRONIZATION

Up to 48 gensets may be paralleled on the same busbar. Smart load management is a standard feature.

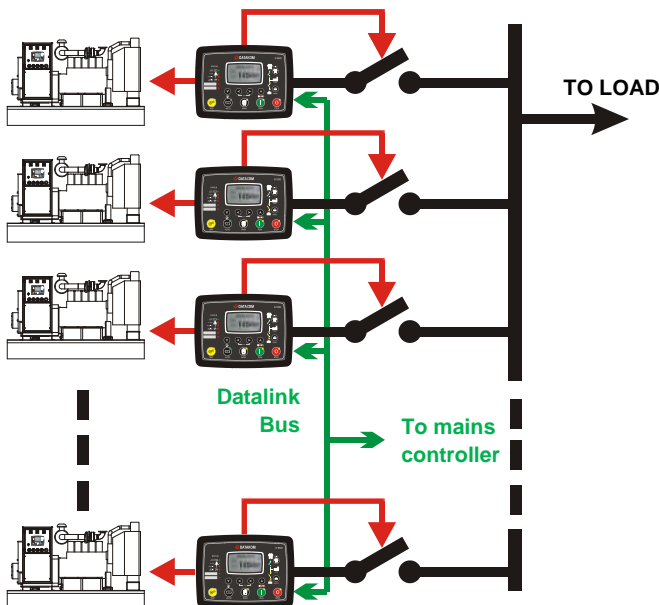

MAINS SYNCHRONIZATION

Up to 16 mains controller per system are supported. Mains controllers provide the REMOTE START signal and handle synchronization of the complete genset system with mains.

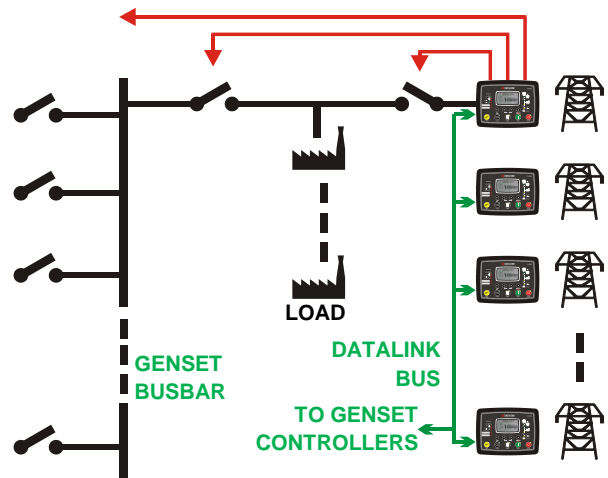

SCOPEMETER & HARMONICS

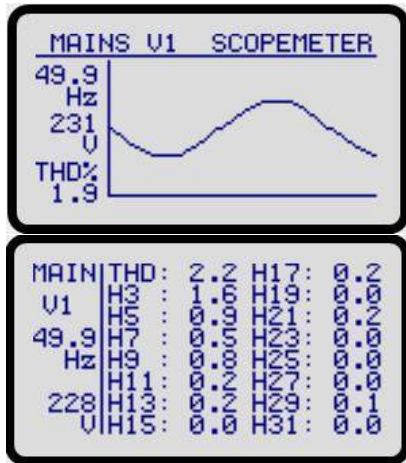

RAINBOW SCADA CENTRAL MONITORING

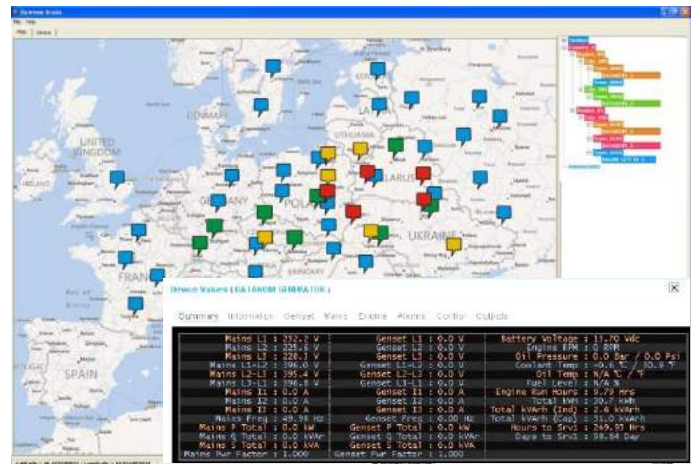

RAINBOW PLUS PROGRAM

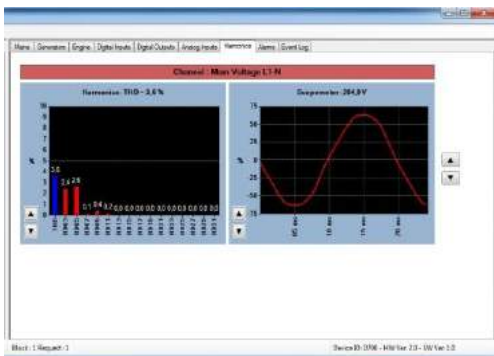

WEB SERVER



TECHNICAL SPECIFICATIONS

Alternator voltage: 0 to 300 V-AC (Ph-N)
Alternator frequency: 0-600 Hz.
Mains voltage: 0 to 300 V-AC (Ph-N)
Mains frequency: 0-600 Hz.
Topology: 1-2-3 phases, with or without neutral
DC Supply Range: 8.0 to 36.0 V-DC.
V-A-cos Accuracy: 0.5% + 1 digit
kW-kVA-kVAr Accuracy: 1.0% + 1 digit
Current consumption: 500 mA-DC max.
Current Inputs: from current transformers. ../5A or ../1A.
Digital inputs: input voltage 0 to 36 V-DC.
Analog input range: 0-5000 ohms.
Mains and genset contactor outputs: 16Amps@250V
DC Outputs: Protected mosfet semiconductor outputs, rated 1Amp@28V-DC
Cranking dropouts: survives 0V for 100ms.
Magnetic pickup voltage: 0.5 to 50Vpk.
Magnetic pickup frequency: 0 to 20000 Hz.
Charge Alternator Excitation: 2W.
Display Screen: 2.9", 128x64 pixels
Ethernet Port: 10/100 Mbps
USB Device: USB 2.0 Full speed
USB Host: USB 2.0 Full speed
RS-485 Port: selectable baud rate (2400-115200baud)

RS-232 Port: selectable baud rate (2400-115200baud)
Operating temperature: -20°C to 70°C (-4 to +158 °F)
 With optional display heater: -40°C to 70°C (-40 to +158 °F)
Storage temperature: -40°C to 80°C (-40 to +176°F)
Maximum humidity: 95% non-condensing.
IP Protection: IP65 from front panel, IP30 from the rear (with gasket)
Dimensions: 211 x 162 x 42mm (WxHxD)
Panel Cut-out Dimensions: 176 x 121 mm minimum.
Weight: 500 g (approx.)
Case Material: High Temperature, non-flammable ABS/PC
Installation: Flat surface mounting on a Type 1 enclosure. Rear retaining plastic brackets.

CONFORMITY

EU Directives Conformity
 -2014/35/EC (low voltage)
 -2014/30/EC (electro-magnetic compatibility)
Norms of reference:
 EN 61010 (safety requirements)
 EN 61326 (EMC requirements)
UL & CSA Compatibility:
 • UL 6200, Controls for Stationary Engine Driven Assemblies (File# - 20140725-E314374)
 • CAN/CSA C22.2 No. 14-13 – Industrial Control Equipment

TYPICAL CONNECTIONS

