



**YANMAR CO.,LTD.**

G3-19128-0031

# **3TNM68-GGE**

**for 6kVA Generator**

**SPECIFICATIONS & DRAWINGS FOR MASS PRODUCTION**

**11.Jun.2008**

**(REV1) 28.Aug.2008**

# Contents

G3-19128-0031



Drawing No.	Part No.	Name	Qty.	Remarks
B3-19128-0050		Out line		
①E3-19125-0020		Wiring Diagram		
Z3-19128-0010		Detail of Flywheel		
G3-19128-0031		Scope of supply		
		LOOSE PARTS		
	114110-07760	LABEL, FUEL OIL CAUT	1	
	119515-13200	GASKET, SILENCER	1	
	129335-55700	SEPARATOR ASSY, WATER	1	
	119643-66900	DIODE	1	
	119650-77910	RELAY ASSY, GLOW	1	
	129211-77920	TIMER, SECTION 1	1	
	0ATNM-U00100	OPERATION MANUAL	1	

**Note :**

①Since the durability of electric parts basically apply to R2 level of JIS D0203, please inform the customer not to clean with steam or high pressure water.

②Electric parts should not mounted on the engine directly (relay, timer etc.) must be kept free from wet & high humidity and be kept with good air ventilation.  
Regarding the vibration of the electrical components, these vibration level must be kept less than 4G.

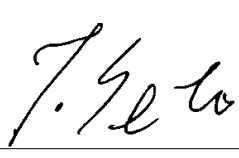
③Since there is the possibility of corrosion problem on engine cylinder liner or other parts, please do not sell and use the engine with EGR valve in other than emission regulated area. (Emission regulated area means North America, Europe and Japan)

Engine Development Dept.	
Manager	
Sec. Manager	
Customer	Checked
Branch	
Exp. Dept.	
Copy	
Total	
Drawn	
	
Sakamoto	

	For Conference	For Apporval	For Installation	Final Drawing
Customer				
Branch				
Exp. Dept.				
Copy				
Total				

★

# ENGINE SPECIFICATIONS

G3-19128-0031

No	Model name	3TNM68-GGE		Remarks	
1	Type	4 cycle, Inline, Water-cooled Diesel			
2	No. of cylinders-Bore×stroke	mm	3-φ68×72		
3	Combustion system	Indirect Injection			
4	Compression ratio	23.5			
5	Displacement	litter	0.784		
6	Rated output	kW(PS)	6.1(8.3)/7.3(9.9)		
		min <sup>-1</sup>	1500/1800		
7	Continuous rating	kW(PS)	5.5(7.5)/6.6(9)		
		min <sup>-1</sup>	1500/1800		
8	Max. torque	N·m	~		
		min <sup>-1</sup>	(+ /)		
9	Specific fuel consumption	g/kW-h(g/PS-h)	max.265(195)	at rated output	
		min <sup>-1</sup>	1800		
10	Standard ambient condition	25°C、750mmHg、30%			
11	Engine speed at no load	Max.	min <sup>-1</sup> 1925	+25/-25	
		Min.	min <sup>-1</sup> 1500	+25/-25	
12	Governorability	Governor type	centrifugal-all speed governor		
		Temporary	%	max.10	load 100% ↓ 0%
		Permanent	%	max.5	
		Recovery time	sec	max.5	
		Stability	min <sup>-1</sup>	max.30	
13	Gradients	Longitudinal	deg	30(25)	intermitted
		Lateral	deg	30(25)	( ) : continuous
14	Firing order	1-3-2-1		order from F.W.	
15	Direction of rotation	counterclockwise		viewed from F.W.	
16	Engine dry weight	kg	approx.104		
17	Fuel injection timing	deg	FIR16(+1/-1)		
18	Fuel system	Fuel type	Diesel oil		
		Fuel injection pump	Bosch in-Line(MC), Yanmar made		
		Fuel injection nozzle	hole type		
		Fuel filter	paper element		
19	Lubrication system	System	forced feed		
		Oil grade	API class CD, SAE grade 10W30		
		Oil pump	trochoid pump		
		Oil filter	paper element		
		Oil capacity	litter	2.5	max.
			litter	1.2	effective.
		Oil pressure	kgf/cm <sup>2</sup>	3	at rated output
kgf/cm <sup>2</sup>	0.6		at low idle		
20	Cooling system	Heat exchanger	none		
		Pressure cap	kgf/cm <sup>2</sup>	0.9	
		Fan	5-φ310		
		Coolant capacity	litter	1	

3TNM68-GGE

## ENGINE SPECIFICATIONS

G3-19128-0031

No	Model name	3TNM68-GGE	Remarks
21	Air cleaner	none	
22	Breather system	closed	
23	Muffler	none	
24	Starting system	Starter	12V-1.2kW
		Battery	46B24
		Starting aid	glow plug(super quick glow)
25	Generator	12V-40A	
26	Engine color	Black	
27	Applied regulation	EPA Tier4,ARB-OR Tier4	

< Career >

REV.1(28.Aug.08)change the wiring diagram.

E3-19125-0010→E3-19125-0020

	W.No.	3TNM68-GGE
--	-------	------------

3TNM68-GGE

## SCOPE OF SUPPLY

G3-19128-0031

No	ENGINE MODEL	3TNM68-GGE	Parts number	Remarks
<b>FUEL SYSTEM</b>				
1	Fuel Injection Pump	installed	719128-51310	MARKED "5C06"
2	Fuel Injection Nozzle	installed	719025-53100	in basic, Mark "FV"
3	Fuel Transfer Pump	installed	129100-52000	
4	Fuel Filter	installed	119833-55620	AUTO_AIR_BREATHER_FILTER
5	Fuel Filter Bracket	installed	119125-55650	
6	Fuel Injection Line	installed	119125-59840	FOR 3TNM68 ,brack
7	Fuel Line(Filter to Pump)	installed	129210-59230	L=205
8	Fuel Pipe (Pump to Filter)	installed	129210-59140	L=380
9	Water Separator	provided	129335-55700	
10	Throttle Lever	installed	119546-61440	
<b>LUB,OIL SYSTEM</b>				
11	Oil Pan	installed	119125-01770	3TNM68_SHALLOW,
12	Oil filler Extension pipe	installed	106760-01770	
13	Breather Pipe	not provided	none	
14	Return Joint,breather	not provided	none	
15	Switch ,lub .oil pressure	installed	114250-39450	CA104_TYPE
16	Dipstick	installed	119125-34800	
17	Guide ,dipstick	installed	119125-34810	3TNM68_STICK
18	Oil filter	installed	119305-35160	
19	Oil Cooler	not provided	none	
<b>COOLING SYSTEM</b>				
20	Radiator	not provided	none	
21	Rubber Isolaters	not provided	none	
22	Pipe A,radiator	not provided	none	
23	Pipe B,radiator	not provided	none	
24	Sub tank(radiator)	not provided	none	
25	Water Pump	installed	119125-42000	LOW_POSI
26	Cooling Fan	installed	119265-44740	Φ 310 push (UI)
27	Spacer ,fan	installed	129457-44760	T=30
28	Guide ,fan	not provided	none	
29	Pully ,fan	installed	119740-42350	D90
30	V-Belt	installed	25132-003400	34inch
31	Switch, water temp.	installed	121250-44901	Switch 110°C
32	Sender, water temp.	not provided	none	
33	Thermostat	installed	119717-49800	71°C
34	Thermostat Cover	installed	124101-49531	Lateral
35	Water Drain Fitting	installed	171056-49120	PLUG
36	3-Way Plug ,cooling water	not provided	none	

<b>ELECTRIC SYSTEM</b>				
37	Starter	installed	119125-77010	12V-1.2kW_HITACHI
38	Alternator	installed	119128-77200	KOKUSAN 40A P TERMINAL W/O SAFETY R
39	Relay ,solenoid	provided	119650-77910	
40	Timer ,solenoid	provided	129211-77920	
41	Engine Shut Off	installed	119653-77950	YAZAKI 12V (STD COUPLER)
42	Starting Aid	installed	119125-77800	GLOW
43	Diode ,solenoid relay	provided	119643-66900	
44	Timer, air heater (glow)	not provided	none	
45	Relay, air heater (glow)	not provided	none	
46	Current Limiter	not provided	none	
47	Safety relay, starter	not provided	none	
<b>PTO SYSTEM</b>				
48	Flywheel Housing or Back plate	installed	119128-01600	
49	Flywheel	installed	119128-21591	
50	Bearing ,retainer	not provided	none	
51	Pully ,crankshaft	installed	119125-21650	φ 100
52	Gear case	installed	119125-01500	68
53	Hydraulic Pump	not provided	none	
54	Device, hydraulic pump	not provided	none	
<b>INTAKE/EXHAUST SYSTEM</b>				
55	Air Cleaner	not provided	none	
56	Bracket ,air cleaner	not provided	none	
57	Manifold ,intake	not provided	none	
58	Joint	not provided	none	
59	Muffler	not provided	none	
60	Gasket ,muffler	provided	119515-13200	
61	Manifold ,exhaust	installed	119125-13140	with silencer stay
62	Bend ,exhaust	not provided	none	
63	EGR Pipe	not provided	none	
64	EGR Valve	not provided	none	
65	EGR Cooler	not provided	none	
66	Turbine	not provided	none	
<b>GAUGE</b>				
67	Drive Unit ,tachometer	not provided	none	
68	Cable ,tachometer	not provided	none	
69	Tachometer	not provided	none	
70	Key Switch	not provided	none	
71	Cover ,terminals	not provided	none	
72	Pilot lamp	not provided	none	
73	Gauge ,oil/water temp	not provided	none	
74	Gauge ,oil pressure	not provided	none	
<b>OTHERS</b>				
75	Filter Wrench ,lub .oil	not provided	none	
76	Filter Wrench ,fuel .oil	not provided	none	

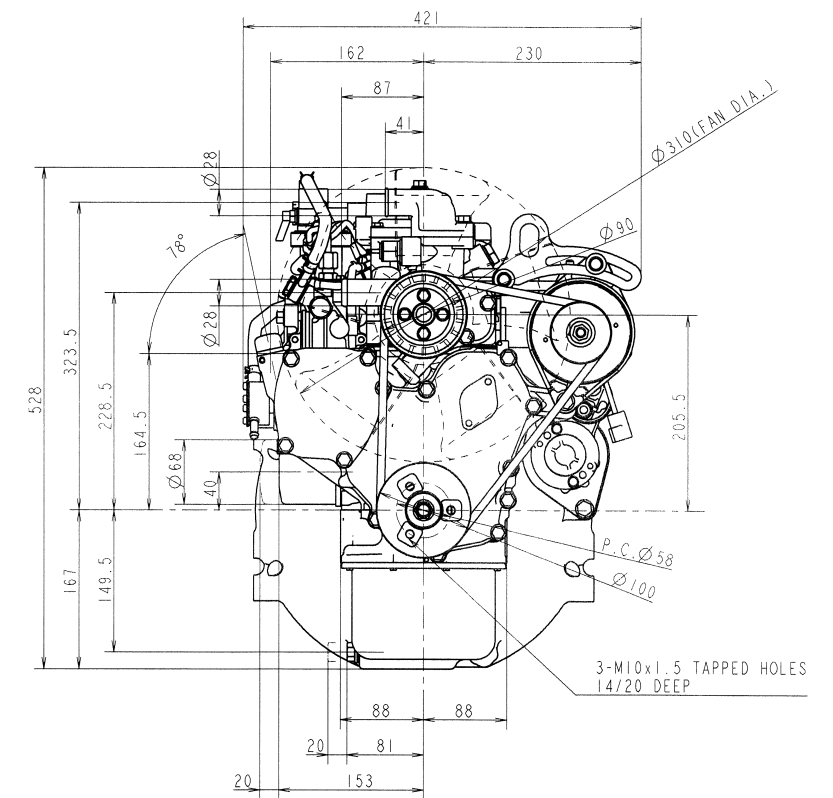
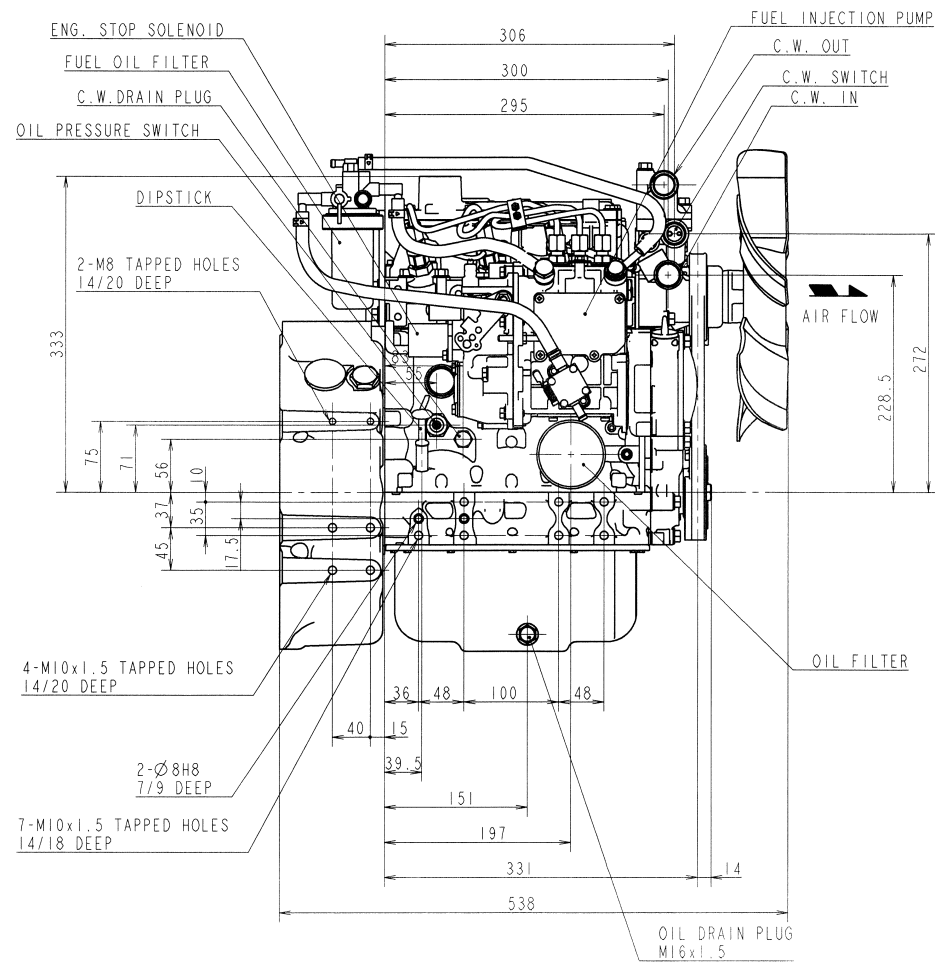
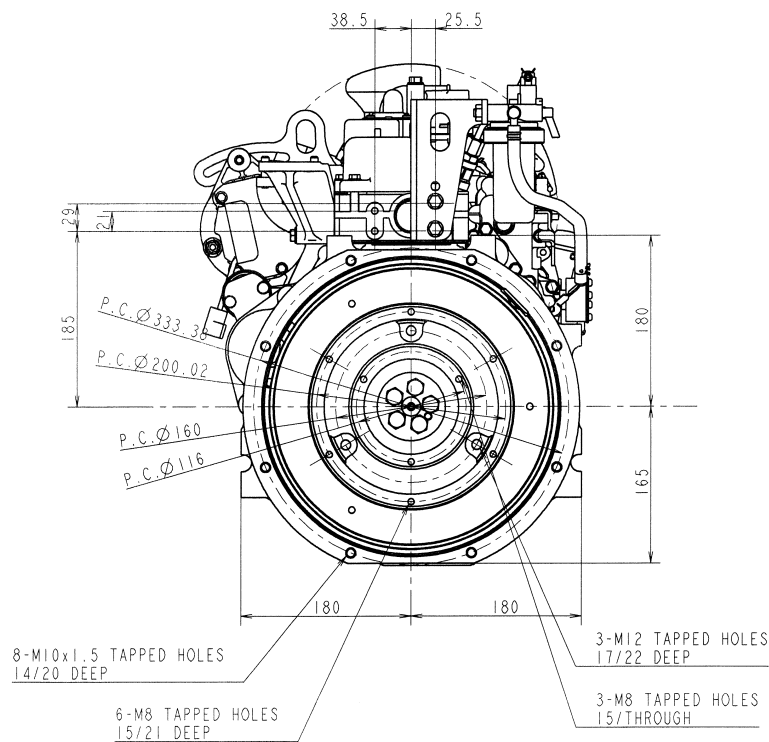
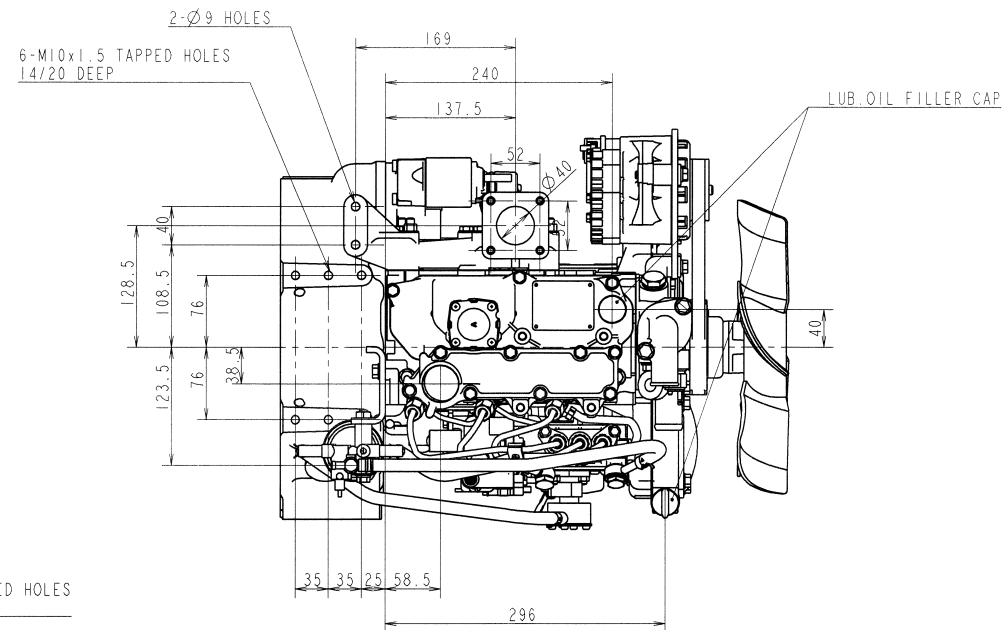
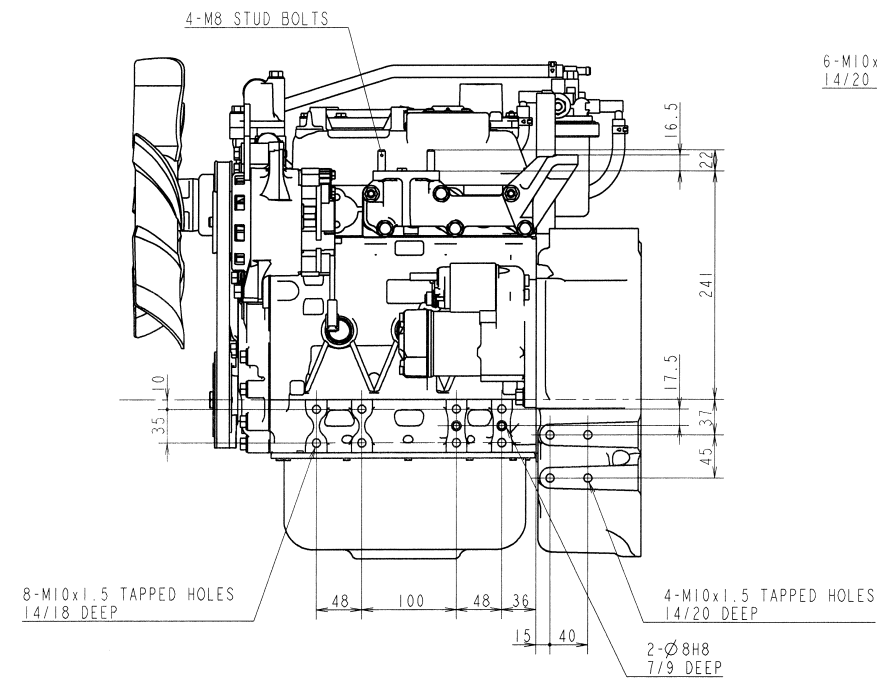

Conform to the Yanmar standard IS-V-0001J concerning "the limitation of the environmental burden material" for the use of the environmental burden material of this part.

本図面の環境負荷物質の使用に関し、YIS-V-0001J(環境負荷物質の使用制限)を準拠してください。

3D-CAD

NOTICE

GEOMETRICAL TOLERANCE	SYMBOL
KIND OF TOLERANCE	
STRAIGHTNESS TOLERANCE	
CIRCULARITY TOLERANCE	
PROFILE OF LINE TOLERANCE	
FLATNESS TOLERANCE	
CYLINDRICITY TOLERANCE	
PROFILE TOLERANCE OF SURFACE	
PARALLELISM TOLERANCE	
PERPENDICULARITY TOLERANCE	
ANGULARITY TOLERANCE	
POSITIONAL TOLERANCE	
COINCIDENCE TOLERANCE	
SYMMETRY TOLERANCE	
CHIRALITY TOLERANCE	
FORM TOLERANCE	

WEIGHT (RAW)	(± %)	kg
WEIGHT (CALC.)	(± %)	kg
S. ENGINEER	MANAGER	3TNM MODEL 68-GGE
CHECKED	SPECIALIST	QTY 1
DESIGNED	DRAWN	DATE: Y.M.D NAME
<p><b>YANMAR</b></p> <p>POWER SYSTEM OPERATIONS DIV., YANMAR CO., LTD.</p>		
REV.	REV. 2	CODE B3-19128-0050

C. MANAGER'S MANAGER

Y. H. 26

SCALE 1:4

MATERIAL

OUTLINE

MARK	COLOR
B	Black
W	White
R	Red
L	Blue
G	Green
Y	Yellow
Br	Brown
Lg	Light Green
Sb	Sky blue
O	Orange
P	Pink
Gr	Gray
R/W	Red/White

形状寸法コード GT.CODE 真円度・円筒度八、半径法

面来歴 CAREER REV.1 (26. Aug. 08) ADD THE SAFETY RELAY, OPTION (YDSTX-08089)

SAFETY RELAY OPTION

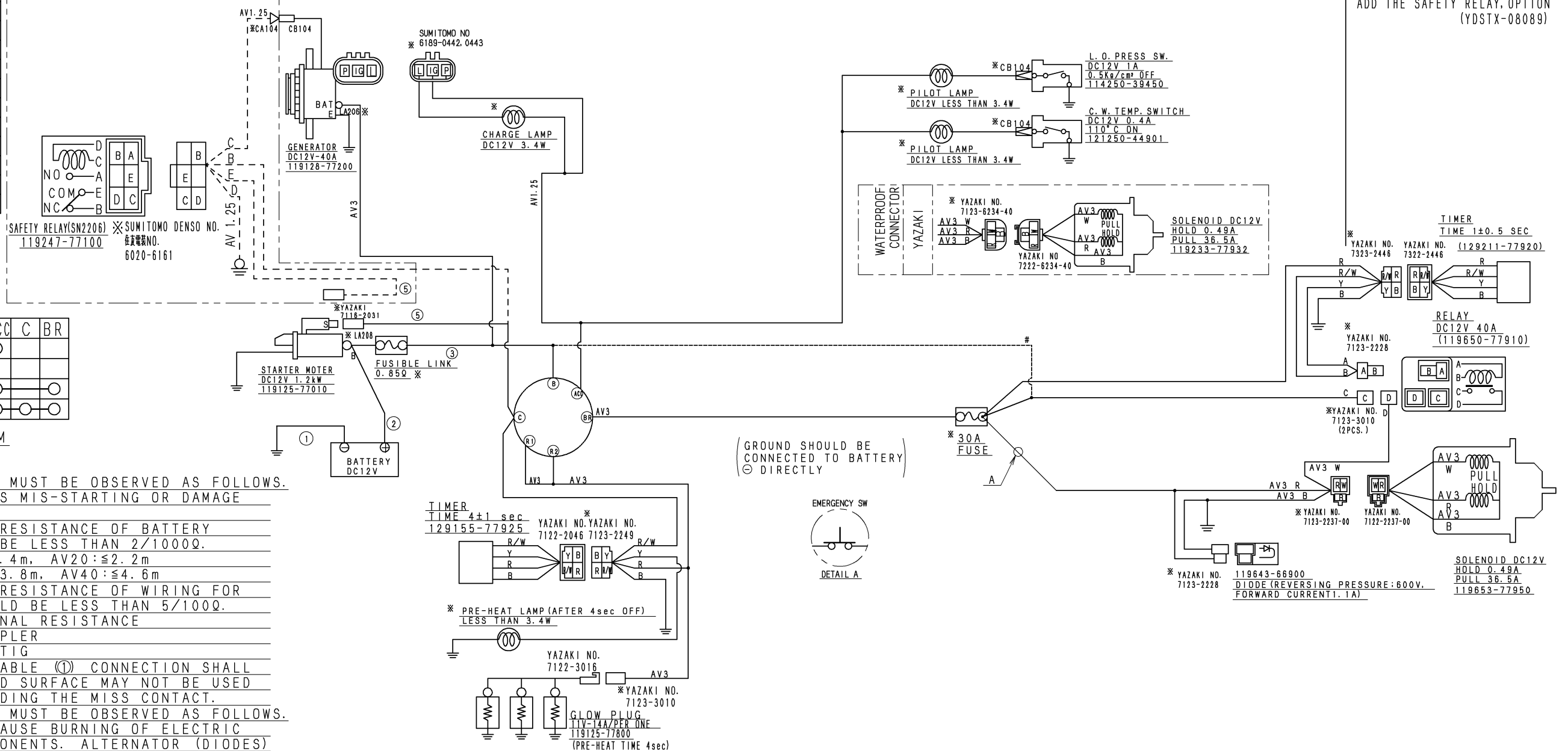

	B	R1	R2	ACC	C	BR
PRE-HEATING	○	○	○	○	○	○
OFF	○	○	○	○	○	○
ON	○	○	○	○	○	○
START	○	○	○	○	○	○

KEY SW. DIAGRAM

NOTES

1. WIRING OF STARTER MUST BE OBSERVED AS FOLLOWS. OTHERWISE IT CAUSES MIS-STARTING OR DAMAGE OF STARTER MOTOR.
  - 1-1. TOTAL ELECTRIC RESISTANCE OF BATTERY CABLE (①+②) SHOULD BE LESS THAN 2/1000Ω. REFERENCE: AV15: ≤1.4m, AV20: ≤2.2m, AV30: ≤3.8m, AV40: ≤4.6m
  - 1-2. TOTAL ELECTRIC RESISTANCE OF WIRING FOR STARTER (③~⑤) SHOULD BE LESS THAN 5/1000Ω. REFERENCE OF TERMINAL RESISTANCE: 15/1000Ω PER COUPLER, 0Ω PER SCREW SETTING
  - 1-3. BATTERY EARTH CABLE (①) CONNECTION SHALL BE ENSURED. PAINTED SURFACE MAY NOT BE USED (FOR EARTHING) AVOIDING THE MISS CONTACT.
2. BATTERY TREATMENT MUST BE OBSERVED AS FOLLOWS. OTHERWISE IT MAY CAUSE BURNING OF ELECTRIC EQUIPMENTS OR COMPONENTS. ALTERNATOR (DIODES) BURNING CAUSED BY BATTERY CABLE CONNECTION REVERSELY IS NOT WARRANTED.
  - 2-1. BATTERY SHOULD BE FIXED BY FITTING. (NOT TO MOVE)
  - 2-2. BATTERY CABLE LENGTH SHOULD BE ADJUSTED PROPERLY AND CLAMPED NOT TO BE CONNECTED REVERSELY.
  - 2-3. NOT LOOSE THE BATTERY CABLE TERMINAL, NOR TURN THE BATTERY SWITCH OFF DURING THE ENGINE RUNNING.
3. ONLY THE SPECIFIED LOAD SHOULD BE APPLIED ON THE ALTERNATOR "L" AND "P" LINE. IT IS NOT ALLOWED TO CONNECT ANY LOAD UNSPECIFIED WITHOUT YANMAR APPROVAL.
4. CHECK ANY SURGE CURRENT OR VOLTAGE OCCURED UNDER NORMAL OPERATIONS AND EXPECTIVE ERRONEOUS OPERATIONS, AND CONFIRM THE CIRCUIT NO SURGE OCCURS. ESPECIALLY PROVIDE THE FLYWHEEL DIODE FOR "C-LOAD" AND DIODE FOR "L-LOAD".

NOTES FOR ENGINE STOP SOLENOID

1. PERMISSIBLE RESISTANCE OF SOLENOID CIRCUIT SHOULD BE LESS THAN 0.07Ω TO GUARANTEE PERMISSIBLE LOWEST VOLTAGE 9V TO WORK SOLENOID (PULL COIL). (TERMINAL RESISTANCE: 15/1000Ω PER COUPLER, 0Ω PER SCREW SETTING. COUPLER RESISTANCE OF SOLENOID DOESN'T NEED TO BE COUNTED) REFERENCE: AV2 (0.0088Ω/m): ≤8.0m... WITHOUT TERMINAL RESISTANCE, AV3 (0.0056Ω/m): ≤12.5m... SAME AS ABOVE. WHEN YOU EXCEED PERMISSIBLE RESISTANCE, ADOPT THE CIRCUIT IMPRESSED FROM THE POWER SUPPLY TO THE SOLENOID DIRECTLY USING A RELAY... REFER TO #
2. HIGH TEMPERATURE PARTS, SUCH AS AN EXHAUST PIPE, SHOULD NOT APPROACH FOR THE PULL POWER FALL OF SOLENOID, AND HEATING PREVENTION OF INNER COIL TEMPERATURE. (PERMISSIBLE AMBIENT TEMPERATURE: -30~100℃)
3. INSTALL FUSE TO PROTECT THE HARNESS AGAINST TROUBLES SUCH AS SHORT CIRCUIT OR CONTINUOUS DRIVE OF PULL-COIL.
4. THE POWER SUPPLY OF SOLENOID MAY NOT BE COMMON WITH THE LINE OF ALTERNATOR INITIAL EXCITATOR AS SHOWN IN THIS DRAWING. (OTHERWISE, SOLENOID MAY LOOSE STOP FUNCTION DUE TO THE POWER SUPPLY FROM ALTERNATOR "L" TERMINAL.)
5. IN CASE OF WATERPROOF CONNECT OR APPLICATION, CONNECTOR SHOULD BE FIXED BY FITTING TO PREVENT LEAD WIRE BREAK.
6. IN CASE OF EMERGENCY STOP OF MACHINE FOR SAFETY WILL BE APPLIED, SWITCH LOCATION SHOULD BE SHOWN AS A.
7. IN CASE OF THE SOLENOID CIRCUIT RESISTANCE WOULD BE LIMIT, # WIRING IS APPLICABLE.

REMARKS

1. \* MARKED PARTS ARE NOT PROVIDED BY YANMAR.

素材質量 WEIGHT (RAW)	(± %)	水圧試験 HYDRAULIC TEST	MPa	小形工 G. MANAGER	部長 MANAGER	技部長
完成質量 WEIGHT (精度%)	(± %)	空圧試験 PNEUMATIC TEST	MPa			
主席	長 SEC. MANAGER 山田	機種 MODEL	3TNW 3TNW 68 72	尺度 SCALE	SCALE OUT	
検図 CHECKED 榎井	機能担当者 SPECIALIST 野内	個数 QTY.	1 1	材質 MATERIAL		
設計 DESIGNED M. Sakamoto	製図 DRAWN Y. Sugimoto	年月日 DATE 2008 6. 26	名称 NAME WIRING DIAGRAM			
YANMAR CO., LTD.			REV. 1	A2		
POWER SYSTEM OPERATIONS DIV.			コード CODE E3-19125-0020	(C)		



NEED	PURCHASING SPECIFICATION	REQUEST FOR APPROVAL	DELIVERY DRAWING	INSPECTING STANDARD	QC-PROCESS																						
GEN. TOL.	OUTSIDE	INSIDE	CAST WALL THICKNESS	NOMINAL DIM. DIVISION	5 TO	10 TO	18 TO	30 TO	L-CAST	120 TO	120 TO	250 TO	250 TO	400 TO	400 TO	800 TO	800 TO	1600 TO	1600 TO	0.5 TO	0.5 TO	6 ±0.1	400 TO	400 TO	1000 ±0.8	10 MAX	±1 DEG.
DRAFT ANG.	2/100	3/100		SANDMOLD	5 MAX	= 10	= 18	= 30		±1.5	±2.0	±3.0	±4.0	±5.0	±7.0					6 TO	6 TO	30 ±0.2	1000 TO	1000 TO	±2000 ±1.2	10 TO	= 50 ±30MIN
	3/100			SHELL	±0.8	±1.0	±1.5	±2.0	±2.0	±1.0	±1.5	±2.0	±3.0	±4.0	±6.0					30 TO	30 TO	120 ±0.3	2000 TO	2000 TO	±4000 ±2.0	50 TO	= 100 ±20MIN
																				120 TO	120 TO	400 ±0.5			120 TO	= 400 ±10MIN	
																									400 MIN	± 5MIN	

FILE NAME: Z3-19128-0010.DRW

3RD ANGLE PROJECTION

CAREER

revl(07.11.14)Change the clutch size of Flywheel (YDSTX-07154)

FIGURE DIMENSION	GT. CODE
	○ AND ∅ : RADIAL

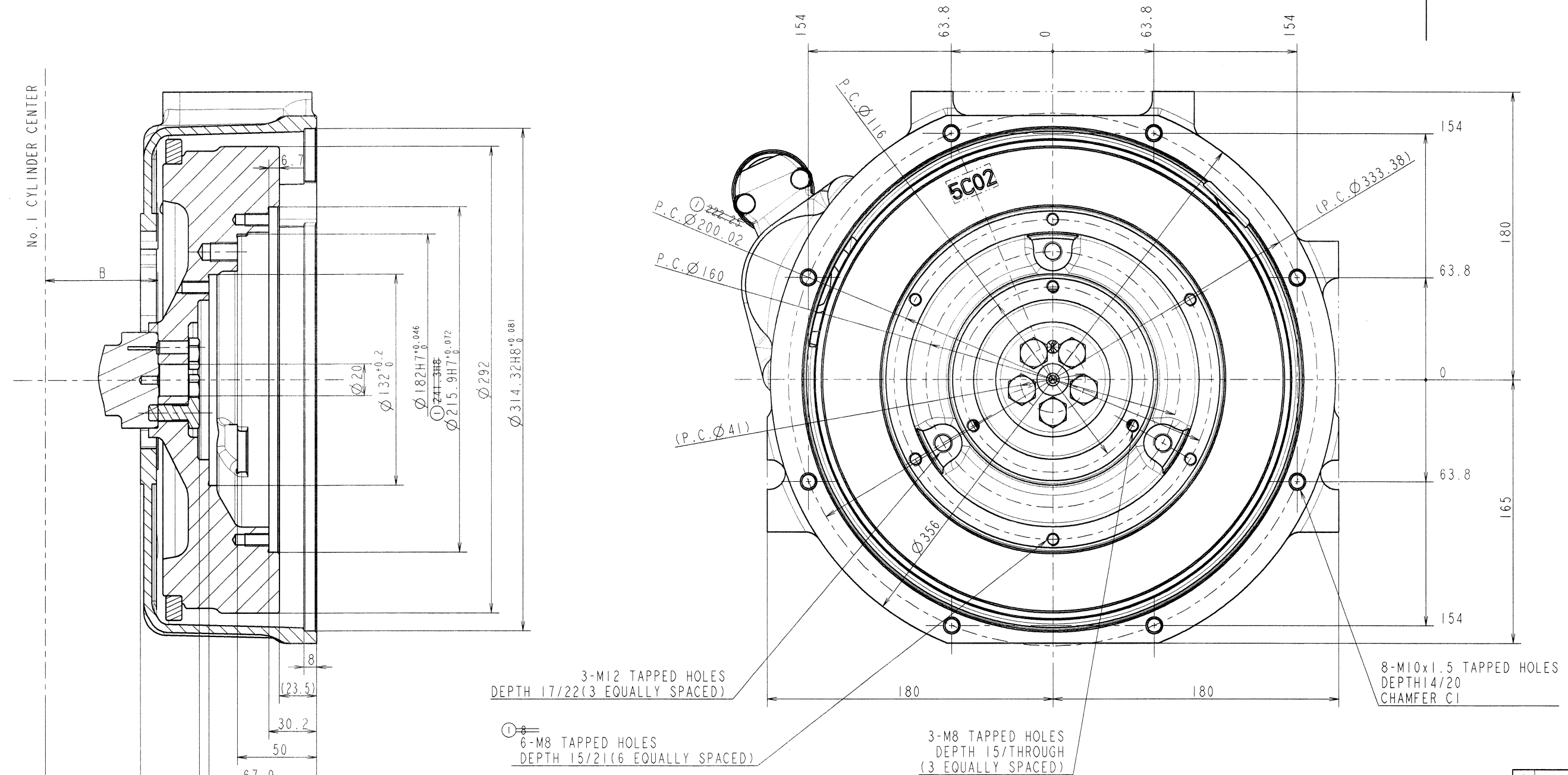

MODEL	DIMENSION A	DIMENSION B	FW. HOUSING	FLYWHEEL CMP	FLYWHEEL
3TNM68	60	71	119128-01600	119128-21591	119128-21401
3TNM72	63	74	↑	↑	↑

WEIGHT (RAW)	kg (± %)	C. MANAGER		S. MANAGER	
WEIGHT (CALC.)	46.974kg (± %)	P. Kato		SCALE 1:2	
S. ENGINEER	MANAGER	MODEL	3TNM68	3TNM72	MATERIAL
<i>Y. Niwa</i>	<i>K. Yamada</i>		-HGE	-HGE	
CHECKED	SPECIALIST	QTY	1	1	
<i>K. Yokoi</i>		直結音信洋田			
DESIGNED	DRAWN	DATE: Y.M.D	NAME		
<i>M. Sakamoto</i>	<i>n. Wakizaka</i>	2007.8.10	DETAIL OF COUPLING		
<b>YANMAR</b>		rev. 1	CODE		DRAW SIZE
POWER SYSTEM OPERATIONS DIV., YANMAR CO., LTD.			Z3-19128-0010		A2

Conform to the Yanmar standard YIS V-0001J concerning "Use limitation of the environmental burden material" for the use of the environmental burden material of this part.

本製品の環境負荷物質の使用に際しては、YIS V-0001J(環境負荷物質の使用規制)を遵守すること。

3D-CAD	NOTICE
GEOMETRICAL TOLERANCE	KIND OF TOLERANCE
SYMBOL	SYMBOL
FORM	FORM
ORIENTATION	ORIENTATION
POSITIONAL TOLERANCE	POSITIONAL TOLERANCE
ANGULARITY TOLERANCE	ANGULARITY TOLERANCE
PARALLELISM TOLERANCE	PARALLELISM TOLERANCE
PERPENDICULARITY TOLERANCE	PERPENDICULARITY TOLERANCE
CONCENTRICITY TOLERANCE	CONCENTRICITY TOLERANCE
SYMMETRY TOLERANCE	SYMMETRY TOLERANCE
STEP-OUT TOLERANCE	STEP-OUT TOLERANCE
TOTAL TOLERANCE	TOTAL TOLERANCE

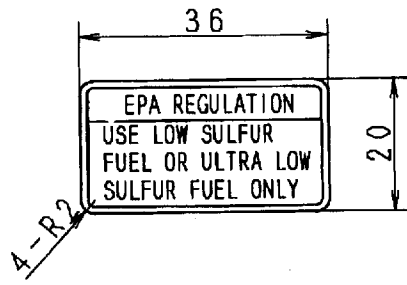

t = 0.05

LABEL		
ネンリョウチュウイラベル		
ENG. MODEL	<b>YANMAR</b> ENGINE PRODUCT OPERATIONS DIV., YANMAR CO., LTD.	CODE 114110-07760

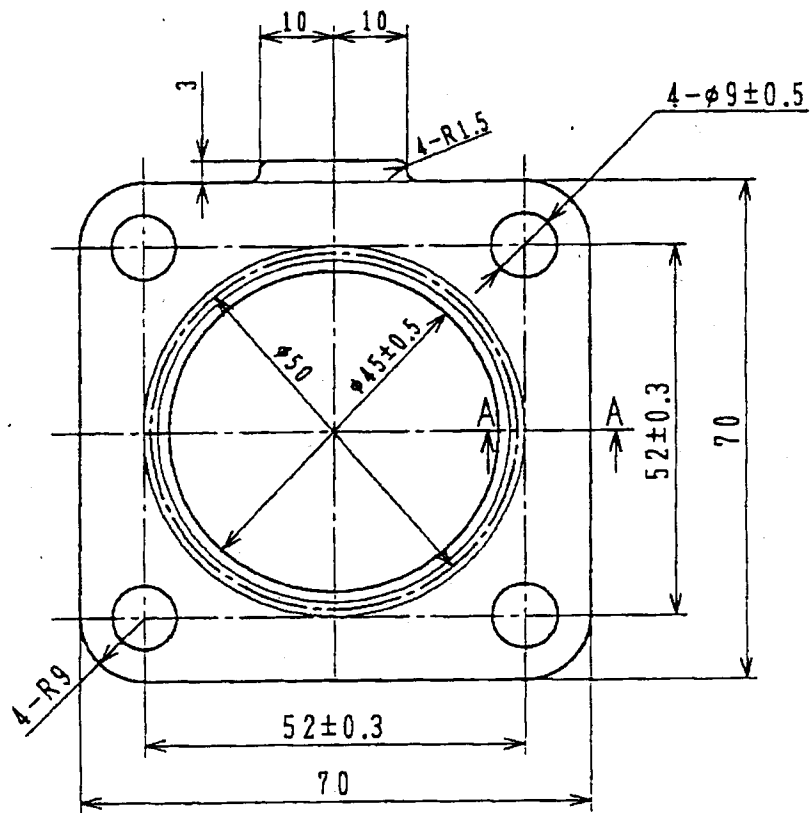

YANMAR CO., LTD

PARTS NAME	Gasket, exhaust
PARTS CODE	119515-13200

**YANMAR CO., LTD.**

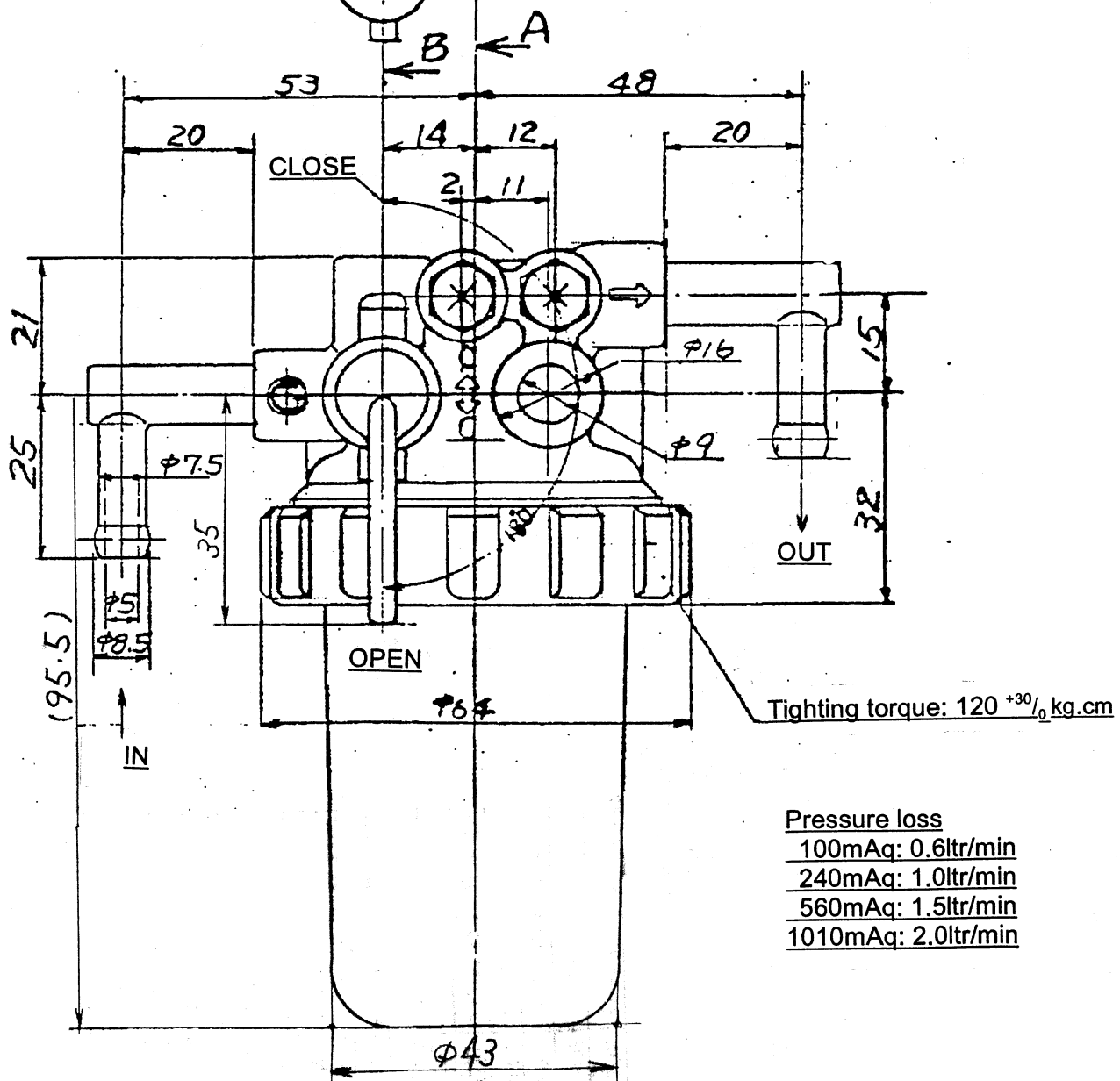
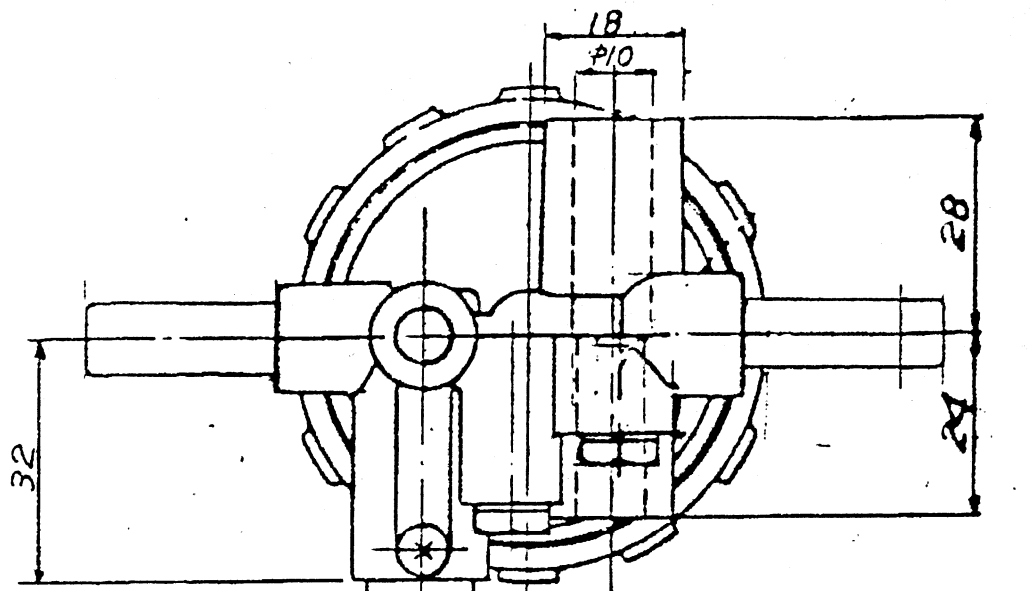

**WATER SEDIMENTER**

**油水分離器**

YANMAR DIESEL ENGINE CO.,LTD

DWG  
No.

129335-55700

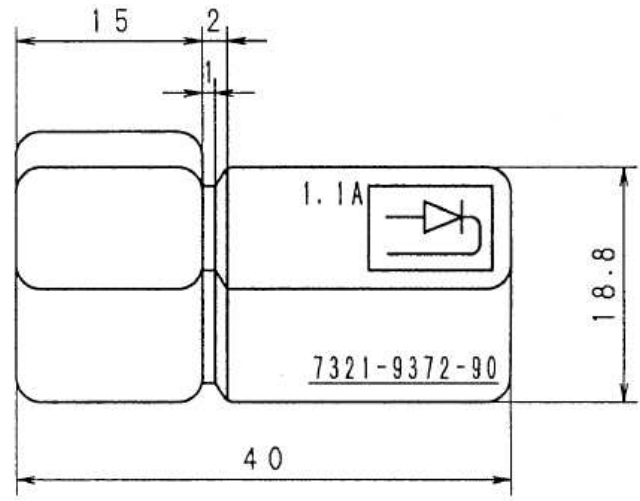
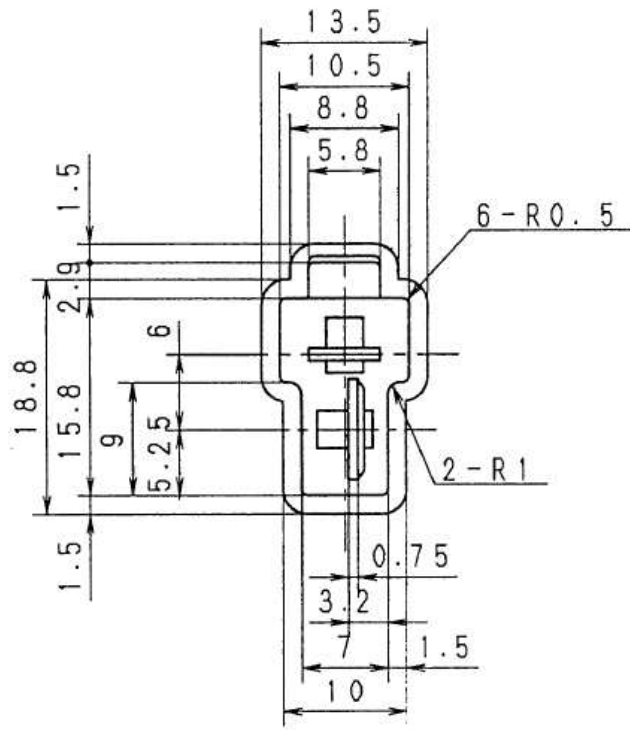

Mate coupler : 7123-2228  
 Mate terminal : 7116-2090

YANMAR CO., LTD	
部品名称 PART	DIODE
PART No.	119643-66900

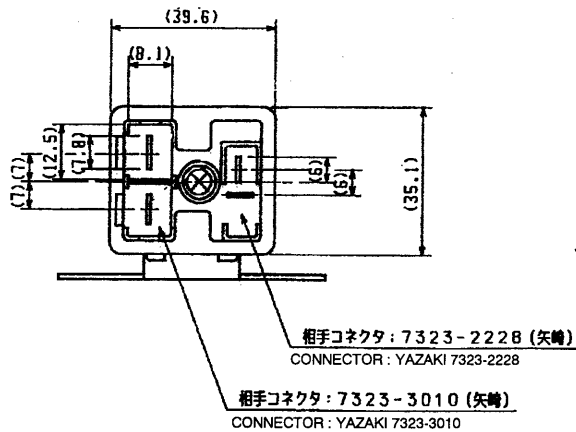
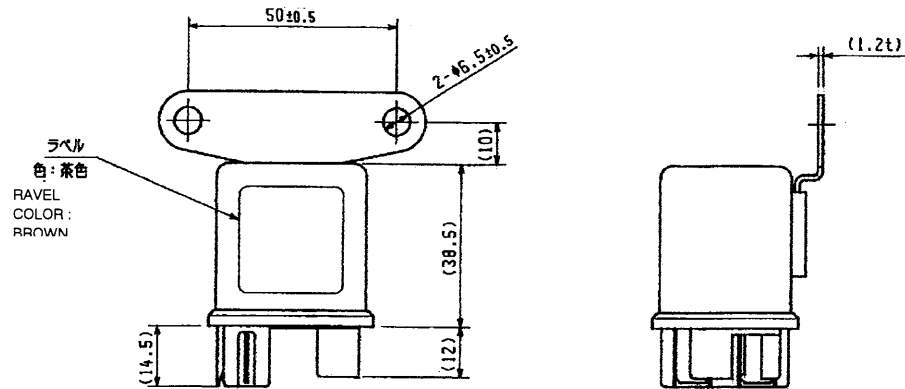

仕様

1. 定格電圧 : DC12V
2. 連続定格 : 10 MIN.
3. コイル抵抗値 : 37Ω
4. インダクタンス : 66mH (at 1kHz)

SPECIFICATIONS

1. RATED VOLTAGE : DC12V
2. MAXMUM OPERATING TIME : 10 MIN.
3. COILE RESISTANCE : 37 ohm
4. INDUCTANCE : 66mH (at 1kHz)

YANMAR DIESEL ENGINE CO., LTD. ENGINE DEVELOPMENT DEPT.	
MODEL	TNE SERIESE
部品名称	グローリレー
NAME	GLOW RELAY
PART No.	119650-77910

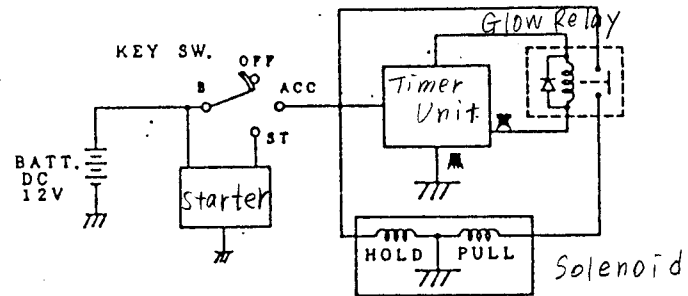
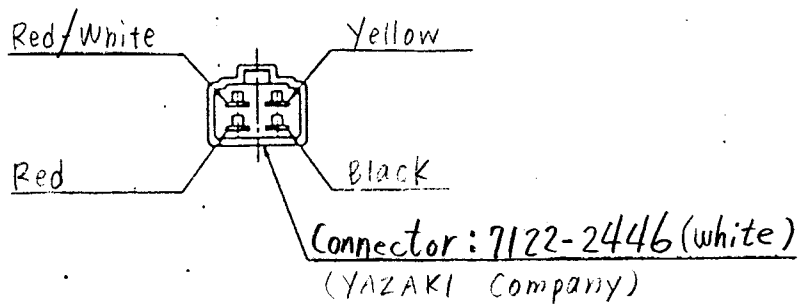
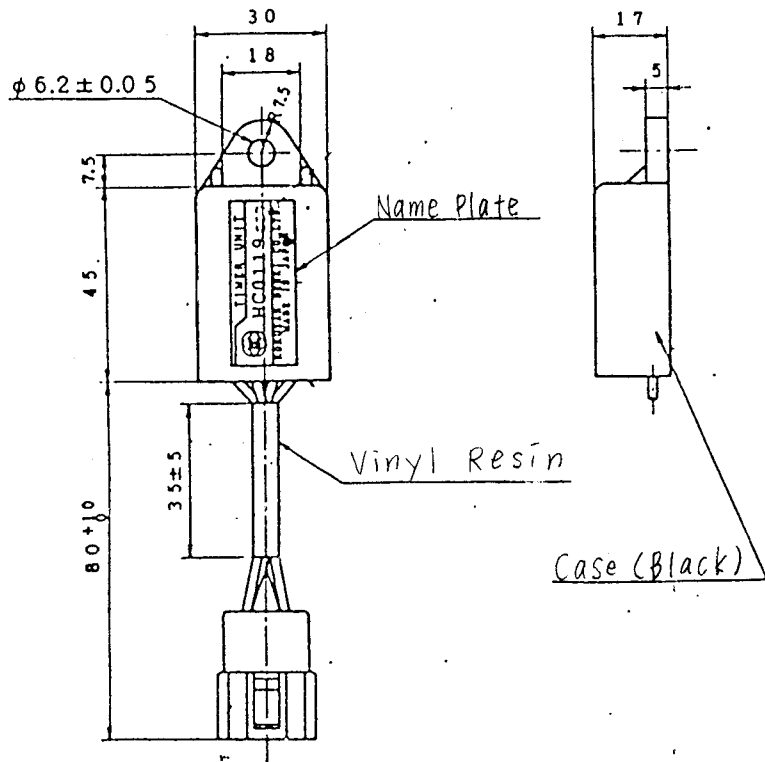

	B	ACC	ST
OFF			
ON	○	○	
ST	○	○	○

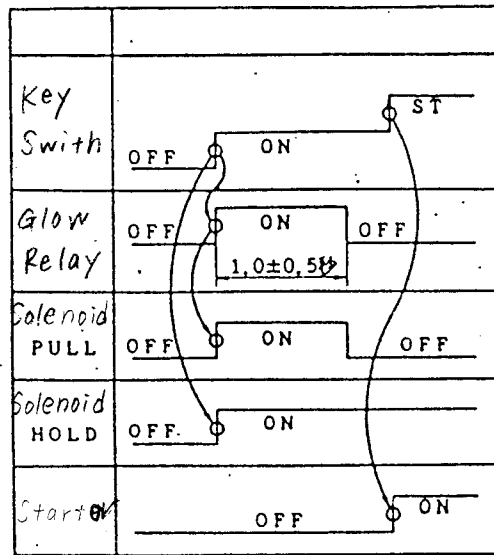

NAME	Timer (1 second)
CODE	129211-77920