

Technical Data

400 Series

404A-22G1

Electropak

Used for 20kVA generator

Basic technical data

Number of cylinders	4
Cylinder arrangement	Vertical in-line
Cycle	four stroke
Induction system	Naturally aspirated
Compression ratio	23.3:1
Bore	84 mm
Stroke	100 mm
Cubic capacity	2.216 litres
Direction of rotation	anti-clockwise when viewed from flywheel
Firing order	1, 3, 4, 2
Estimated total weight (dry)	242 kg

Overall dimensions

-height	841 mm
-length	946 mm
-width	497 mm

Moments of inertia (mk²)

-engine rotational components	0.44 kg m ²
-flywheel	2.55 kg m ²

Centre of gravity

-forward from rear of block	TBA mm
-above centre line of block	TBA mm
-offset to RHS of centre line	TBA mm

Performance

Note: All data based on operation to ISO 3046-1:2002 standard reference conditions

Steady state speed stability at constant load	± 0.75%
Cyclic irregularity	
-at 110% stand-by power	TBA

Test conditions

-air temperature	25°C
-barometric pressure	100 kPa
-relative humidity	31.5%
-air inlet restriction at maximum power (nominal)	3 kPa
-exhaust back pressure at maximum power (nominal)	10.2 kPa
-fuel temperature (inlet pump)	40°C

Sound level

Average sound pressure level for bare engine (without inlet and exhaust) at 1 metre

-all ratings certified to within

If the engine is to operate in ambient conditions other than those of the test conditions, suitable adjustments must be made for these changes. For full details, contact Perkins Technical Service Department.

General installation - 404A-22G1 @ 1500 rev/min

Designation	Units	Type of operation and application	
		Prime	Stand-by
		50Hz	50Hz
Gross engine power	kWb	18.7	20.6
Brake mean effective pressure	kPa	669	650
Mean piston speed	m/s	5	
Engine coolant flow (coolant pump ratio 1.25:1)	l/min	40.3	
Combustion air flow	m ³ /min	1.45	
Exhaust gas flow (max)	m ³ /min	3.64	3.94
Exhaust gas temperature (max)	°C	445	505
Overall thermal efficiency (nett)	%	35	33
Typical genset electrical output (0.8 pf 25°C)	kWe	16.0	17.7
	kVA	20.0	22.1
Assumed alternator efficiency	%	87	
Energy balance			
Energy in fuel (heat of combustion)	kWt	53.0	61.2
Energy in power output (gross)	kWb	18.7	20.6
Energy to cooling fan	kWt	0.3	
Energy in power output (nett)	kWm	18.4	20.3
Energy to coolant and lubricating oil	kWt	17.0	19.6
Energy to exhaust	kWt	14.0	16.6
Energy to radiation	kWt	3.3	4.4

404A-22G1 ElectropaK, left side view

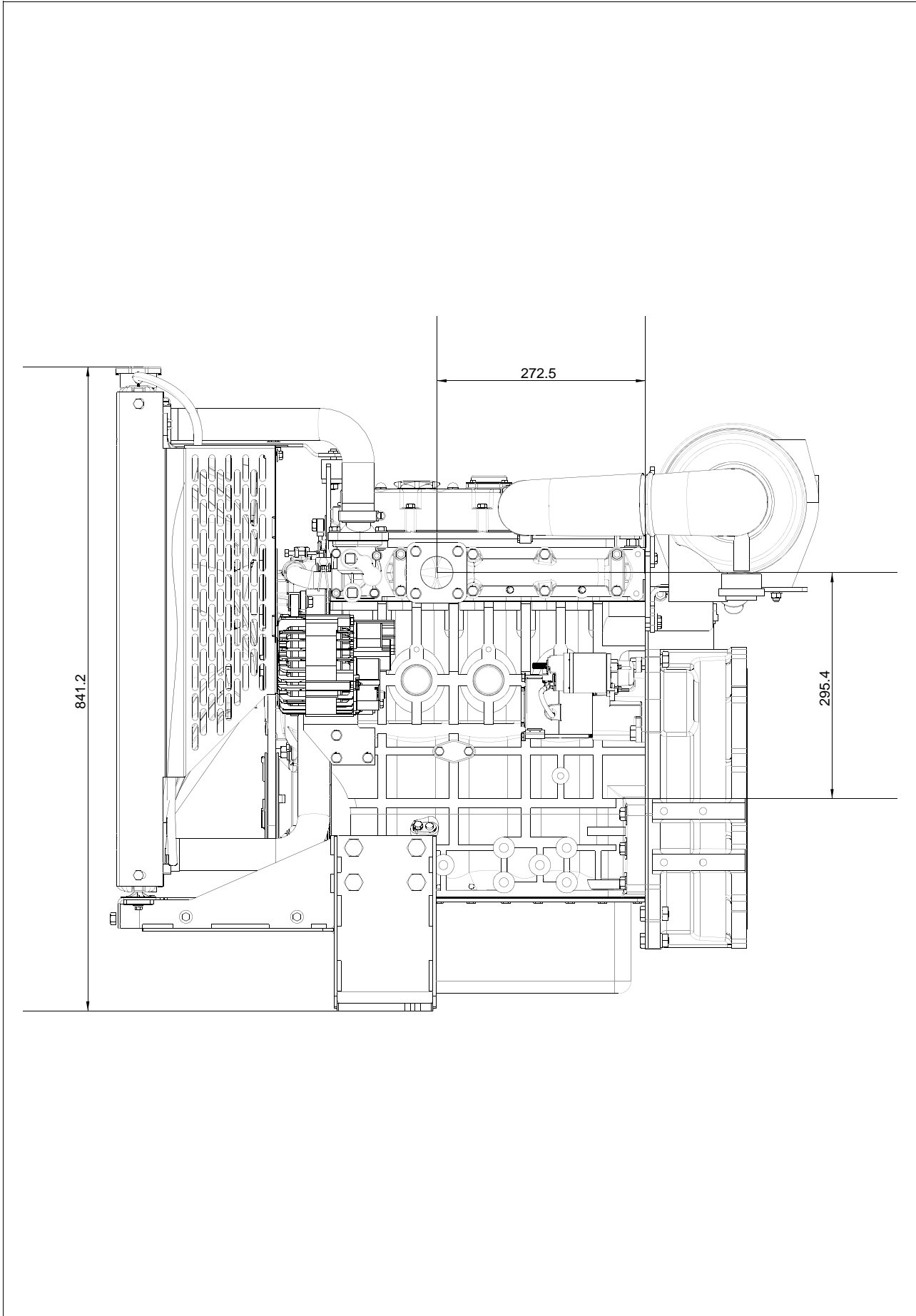

404A-22G1 ElectropaK, front view

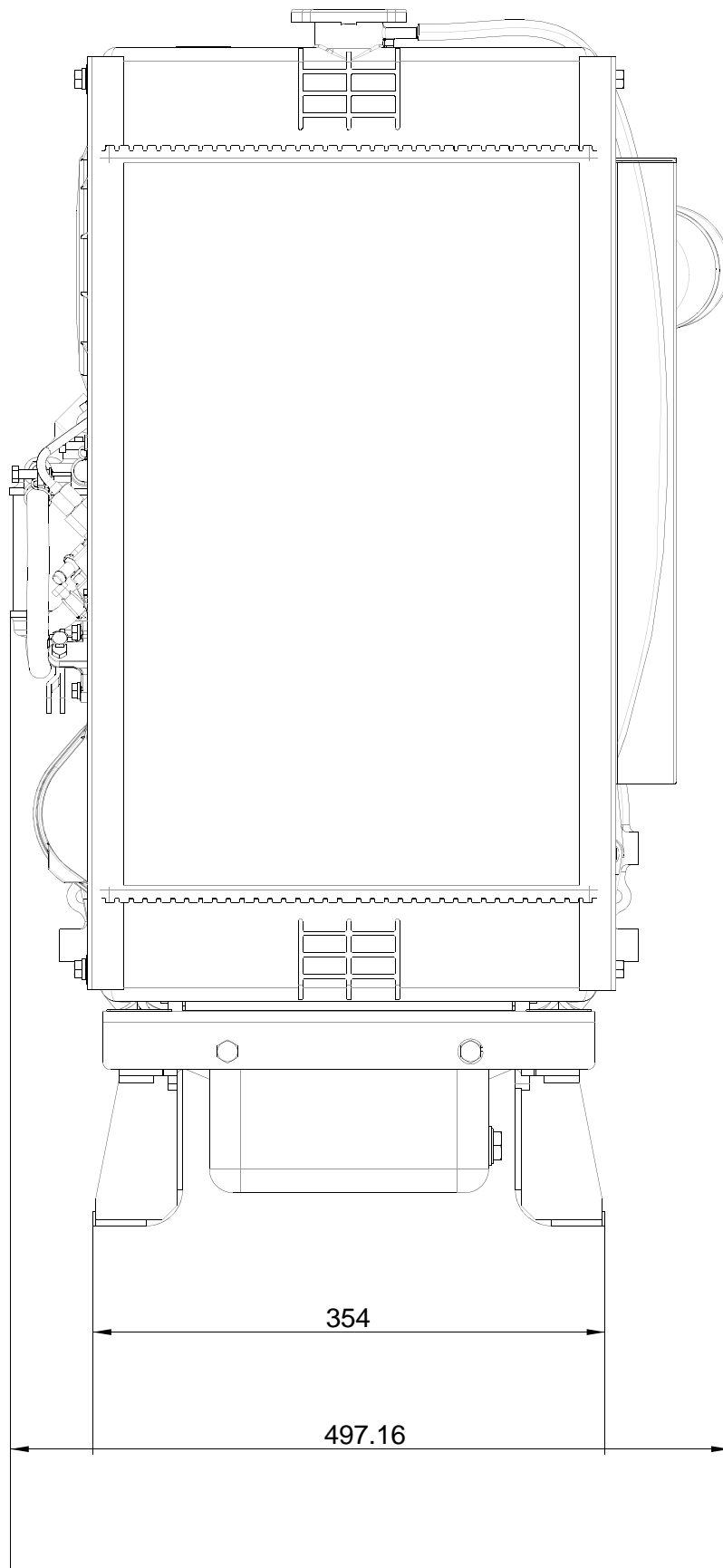

404A-22G1 ElectropaK, right side view

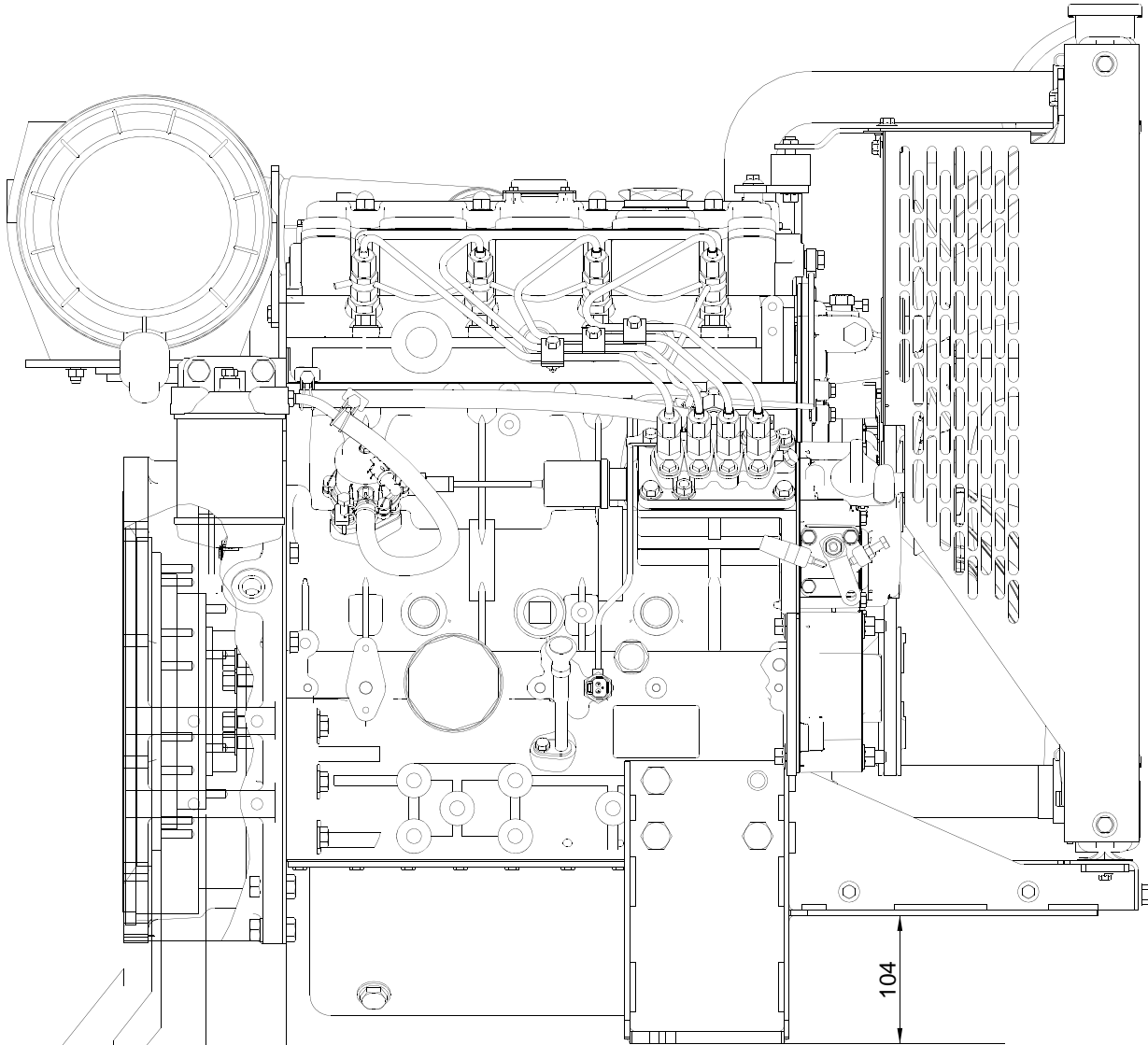

- 132 TO END FW
AND FW HOUSING
- 109
- 102 TO \varnothing 241 SPOT-FACE
 \varnothing 206 PILOT HOLE
- 66 TO \varnothing 174 SPOT-FACE
 \varnothing 120 PILOT HOLE

0

104

404A-22G1 ElectropaK, rear view

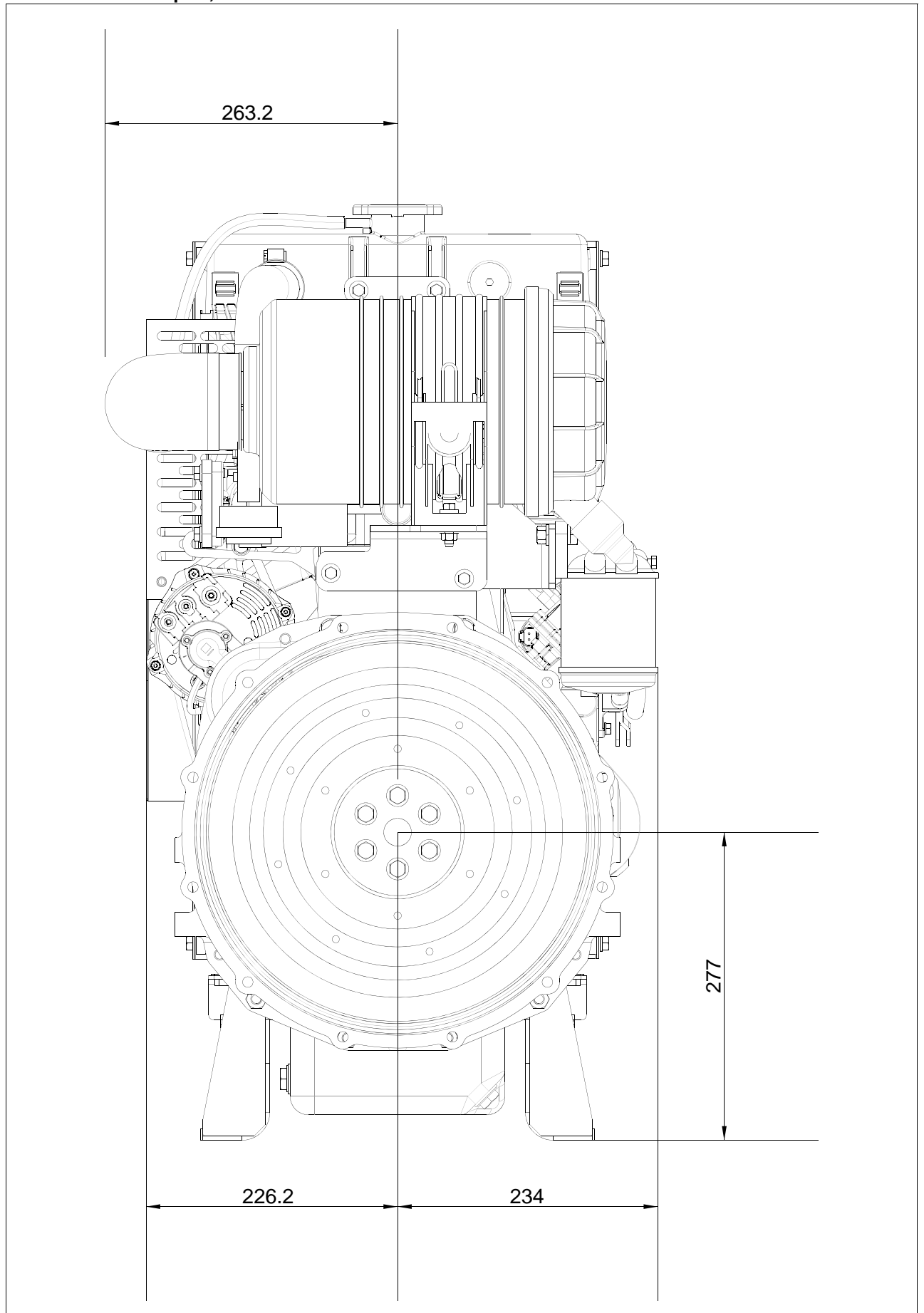

404A-22G1 ElectropaK, plan view

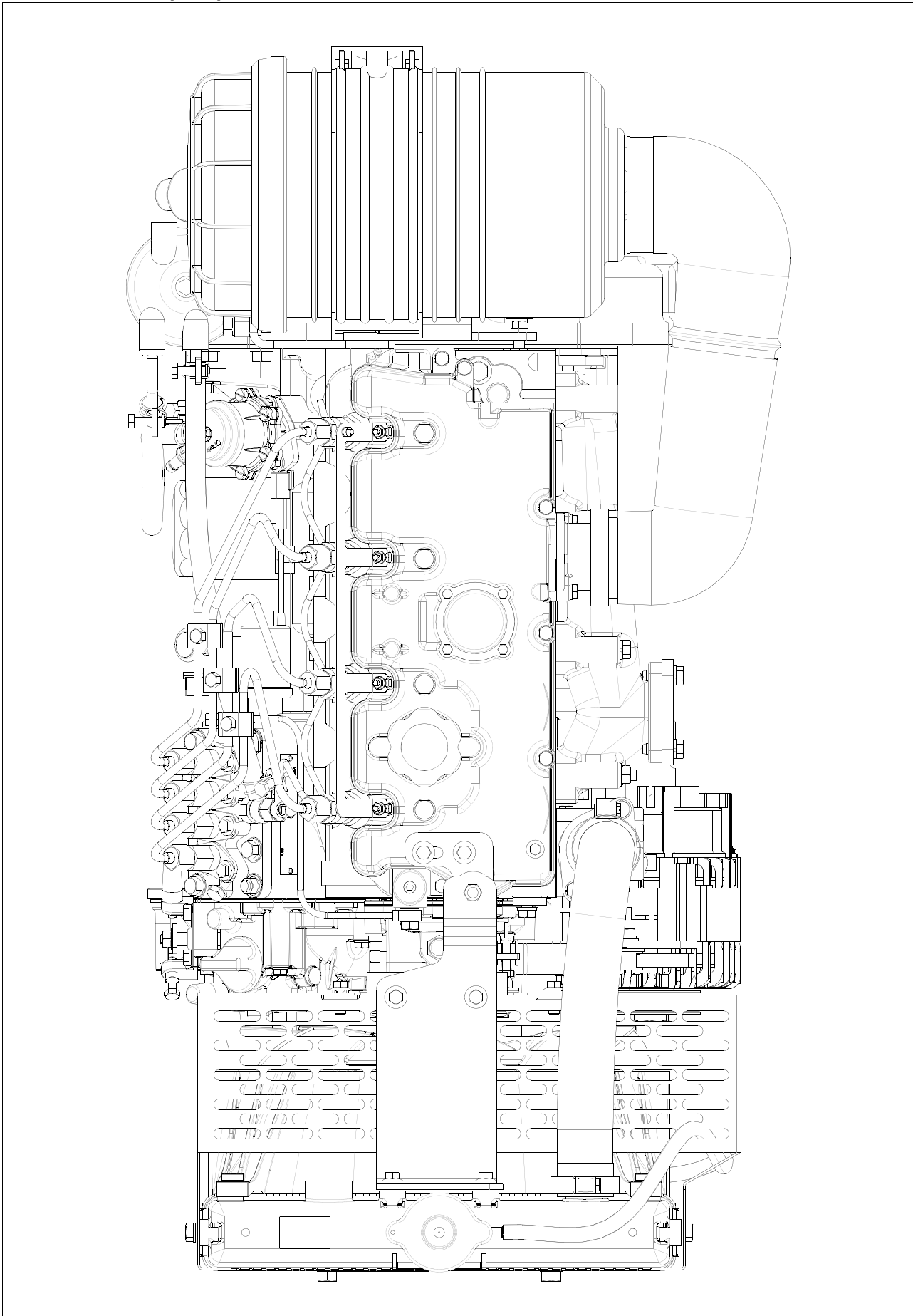

404A-22G1 ElectropaK, underneath view

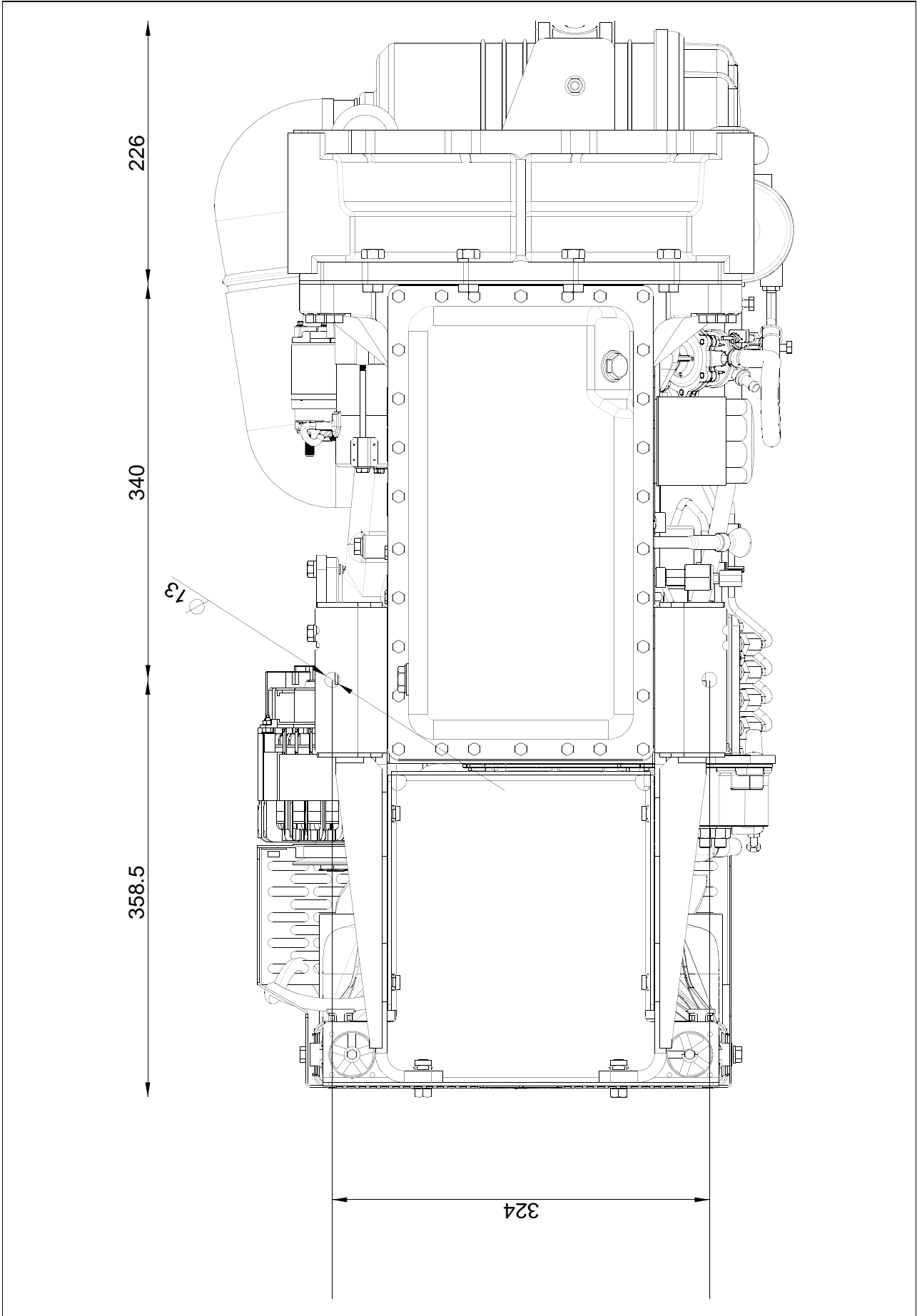

Cooling system

Radiator

-face area ... 0.167 m²
 -rows and materials ... 2 rows, Aluminium
 -matrix density and material ... 14.5 fins per inch, Aluminium
 -width of matrix ... 334.2 mm
 -height of matrix ... 500.0 mm
 -pressure cap setting ... 90 kPa
 Estimated cooling air flow reserve ... 0.125 kPa

Fan

-diameter ... 320 mm
 -drive ratio ... 1.25:1
 -number of blades ... 6
 -material ... Plastic
 -type ... Pusher

Coolant

Total system capacity
 -with radiator ... 7.0 litres
 -without radiator ... 3.6 litres
 Maximum top tank temperature ... 112°C
 Temperature rise across engine ... 7.5°C
 Max. permissible external system resistance ... TBA kPa
 Thermostat operation range ... 82 - 95°C
 Recommended coolant:
 Recommended coolant: 50% anti freeze / 50% water. For complete details of recommended coolant specifications, refer to the Operation and Maintenance Manual for this engine model.

Duct allowance

Maximum additional restriction (duct allowance) to cooling airflow and resultant minimum airflow		
Ambient clearance 50% Glycol	Duct allowance Pa	m ³ /sec
53°C	0	0.67
46°C	125	0.49

Electrical system

-alternator ... 15 amps, 12V
 -starter motor ... 2 kW, 12V

Cold start recommendations

Minimum cranking speed ... 150 rev/min

Minimum starting temperature	Grade of engine lubricating oil	Battery specifications			
		BS3911 Cold start amps	SAEJ537 Cold cranking amps	Number of batteries needed	Commercial ref number
0	20W	540	740	1	647
-15	10W	540	740	1	647
-20	5W	600	780	1	655

Note: Additional information for battery and cable limits can be found in Chapter 6 of the 400 Engine Sales Manual..

Exhaust system

Maximum back pressure ... 10.2 kPa
 Exhaust outlet size ... 42 mm

Fuel system

Type of injection ... Indirect injection
 Fuel injection pump ... Cassette type
 Fuel injector ... Pintle nozzle
 Nozzle opening pressure ... 14.7 MPa
 Max. particle size ... 25 microns

Fuel lift pump

-type ... mechanical (camshaft driven)
 -flow/hour ... 63 litres/hr
 -pressure ... 10 kPa
 Maximum suction head ... 0.8 m
 Maximum static pressure head ... 3.0 m
 Governor type ... Mechanical

Fuel specification

USA Fed Off Highway - EPA2D 89.330-96
 Europe Off Highway - CEC RF-06-99
Note: For further information on fuel specifications and restrictions, refer to the OMM Fuels section for this engine model.

Fuel consumption

Power rating%			
g/kWh (litres/hr)			
110	100	75	50
244 (6.1)	237 (5.3)	238 (4.0)	258 (2.9)

Induction system

Maximum air intake restriction

- clean filter 3.0 kPa
- dirty filter 6.4 kPa
- air filter type Dry element type

Lubrication system

Lubricating oil capacity

- Max. sump capacity 10.6 litres
- Min. sump capacity 8.9 litres
- Maximum engine operating angles
- front up, front down, right side or left side 35° continuous

Lubricating oil pressure

- relief valve opens 352 - 448kPa
- Min. oil pressure 120 kPa
- at maximum no-load speed. TBA
- Oil flow at rated speed 109 litres/min
- Normal oil temperature. 125°C

Recommended SAE viscosity

A single or multigrade oil must be used which conforms API-CH-4 or ACEA E5.

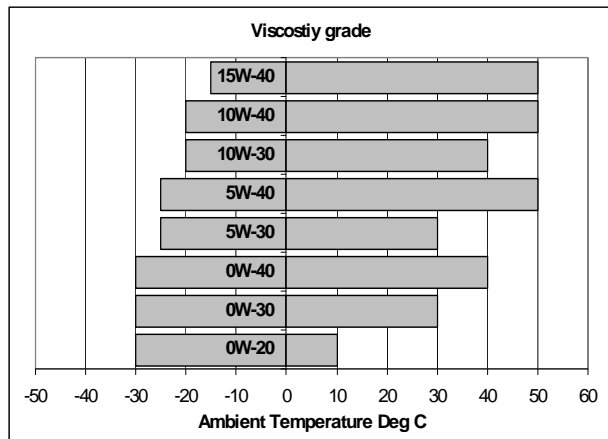

Maximum static bending moment

at rear face of block 1400 Nm

Load acceptance

The below complies with the requirements of classification 3 and 4 of ISO 8528-12 and G2 operating limits stated in ISO 8528-5

Initial load application: When engine reaches rated speed (15 seconds maximum after engine starts to crank)		
Descriptor	Units	50 Hz
% of prime power	%	TBA
Transient frequency deviation	%	TBA
Frequency recovery	Seconds	TBA

The above figures were obtained under the following test conditions:

- minimum engine block temperature TBA°C
 - ambient temperature 25°C
 - governing mode 5%
 - alternator inertia TBA kgm²
 - under frequency roll off (UFRO) point set to 2% Volt / 1% frequency
 - UFRO rate set to 1 Hz below rated speed
 - LAM on/off off
- All tests were conducted using an engine which was installed and serviced to Perkins Engines Company Limited recommendations.

Derate Curves

Derate curves for altitude and humidity can be found in Chapter 6 of the 400 Series Engine Sales Manual.

The general arrangement drawings shown in this data sheet are for guidance only. For installation purposes, latest versions should be requested from the Applications Dept., Perkins Engines Stafford, ST16 3UB United Kingdom.

Notes



Perkins Engines Company Limited

Peterborough PE1 5NA United Kingdom

Telephone +44 (0) 1733 583000

Fax +44 (0) 1733 582240

www.perkins.com

All information in the document is substantially correct at the time of printing but may be subsequently altered by the company.

Distributed by