

Technical Data

400 Series

403A-11G1

Electropak

Used for 10kVA generator

Basic technical data

Number of cylinders 3
 Cylinder arrangement Vertical in-line
 Cycle four stroke
 Induction system Naturally aspirated
 Compression ratio 23:1
 Bore 77 mm
 Stroke 81 mm
 Cubic capacity 1.131 litres
 Direction of rotation anti-clockwise viewed from flywheel
 Firing order 1, 2, 3
 Estimated total weight (dry) 129.2 kg

Overall dimensions

-height 702 mm
 -length 775 mm
 -width (including mounting brackets) 438 mm

Moments of inertia (mk²)

-engine rotational components 0.12 kg m²
 -flywheel 1.51 kg m²

Centre of gravity

-forward from rear of block TBA mm
 -above crank centre line TBA mm
 -offset to RHS of centre line TBA mm

Performance

Note: All data based on operation to ISO 3046-1:2002 standard reference conditions.

Steady state speed stability at constant load ± 0.75%
 Cyclic irregularity
 -at 110% stand-by power TBA

Test conditions

-air temperature 25°C
 -barometric pressure 100 kPa
 -relative humidity 31.5%
 -air inlet restriction at maximum power (nominal) 3 kPa
 -exhaust back pressure at maximum power (nominal) 10.2 kPa
 -fuel temperature (inlet pump) 40°C

Sound level

Average sound pressure level for bare engine (without inlet and exhaust) at 1 metre 76.7 dB(A)
 -all ratings certified to within ± 5%
 If the engine is to operate in ambient conditions other than those of the test conditions, suitable adjustments must be made for these changes. For full details, contact Perkins Technical Service Department.

General installation, 403A-11G1 Electropak @ 1500 rpm

Designation	Units	Type of operation and application	
		Prime	Stand-by
		50 Hz	50 Hz
Gross engine power	kWb	8.6	9.5
Brake mean effective pressure	kPa	610	672
Mean piston speed	m/s	4.1	
Engine coolant flow (Water pump ratio 1.285:1)	l/min	27.3	
Combustion air flow	m ³ /min	0.7	
Exhaust gas flow (max)	m ³ /min	1.66	1.8
Exhaust gas temperature outlet (max)	°C	368	420
Overall thermal efficiency (nett)	%	32	31
Typical genset electrical output (0.8 pf 25°C)	kWe	7.2	8.0
	kVA	9.0	10.0
Assumed alternator efficiency	%	86	
Energy balance			
Energy in fuel (heat of combustion)	kWt	25.9	29.5
Energy in power output (gross)	kWb	8.6	9.5
Energy to cooling fan	kWt	0.2	
Energy in power output (nett)	kWm	8.4	9.3
Energy to coolant and lubricating oil	kWt	8.3	9.5
Energy to exhaust	kWt	7.3	8.0
Heat to radiation	kWt	1.7	2.5

403A-11G1 ElectropaK, left side view

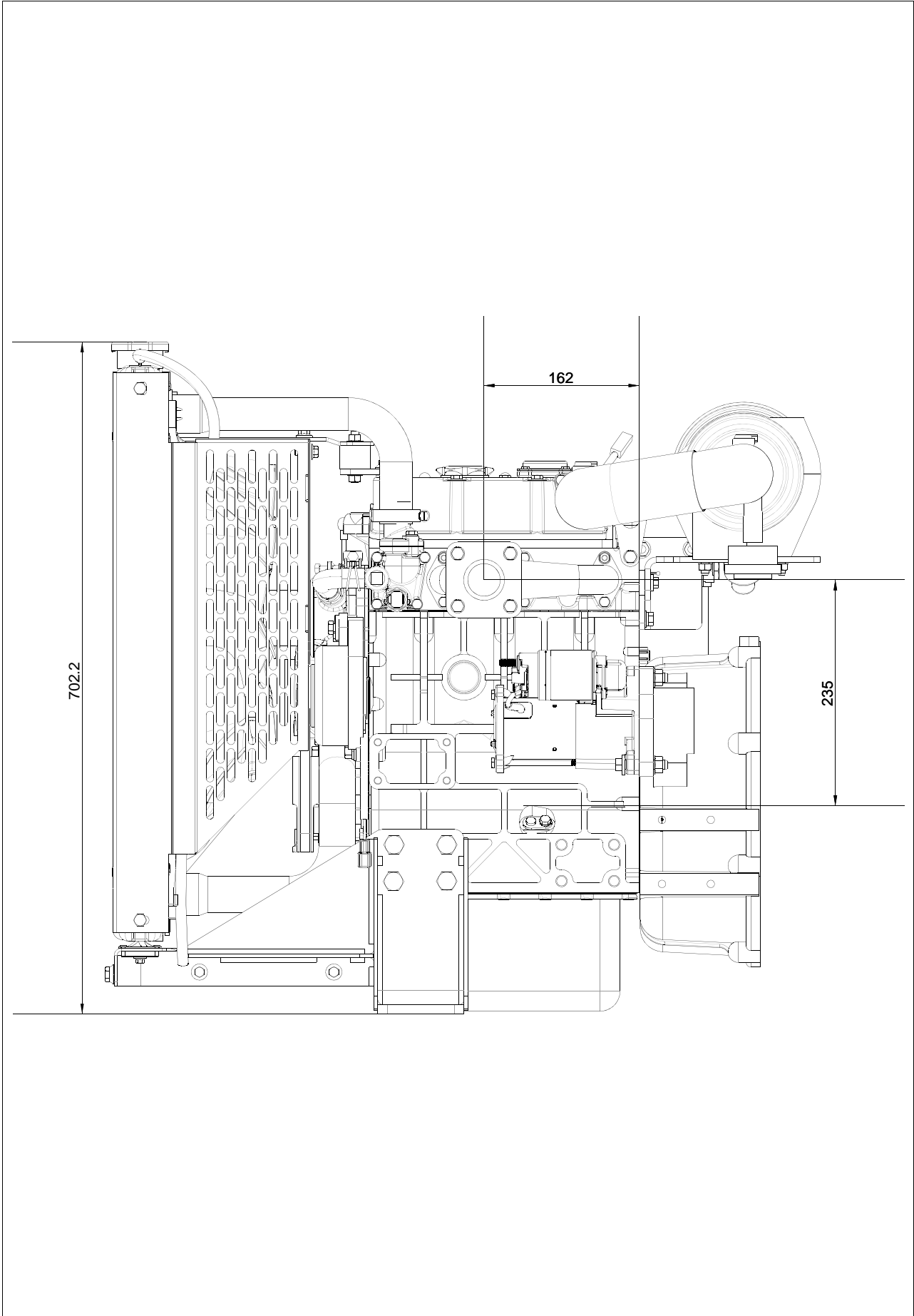

403A-11G1 ElectropaK, front view

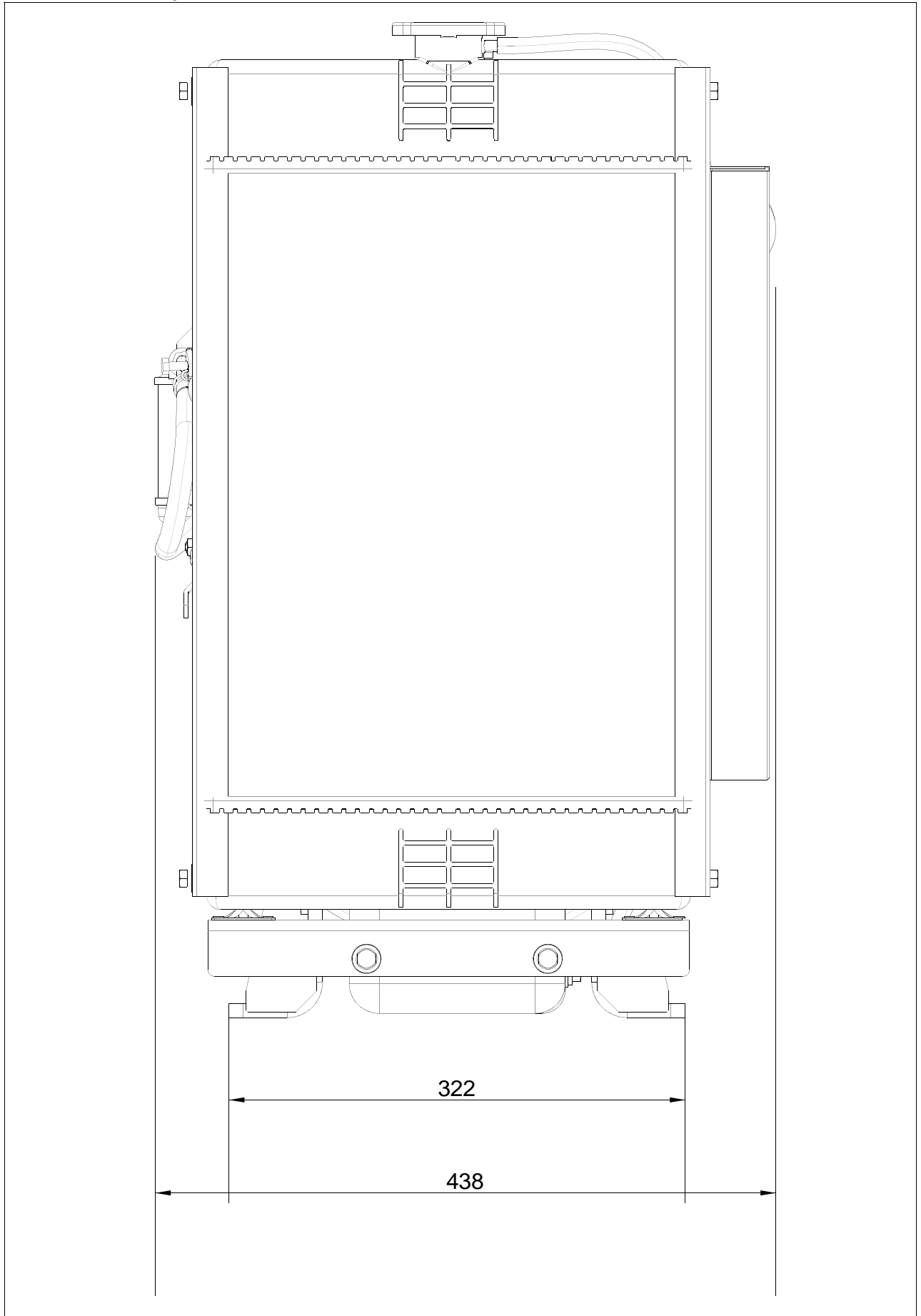

403A-11G1 ElectropaK, right view

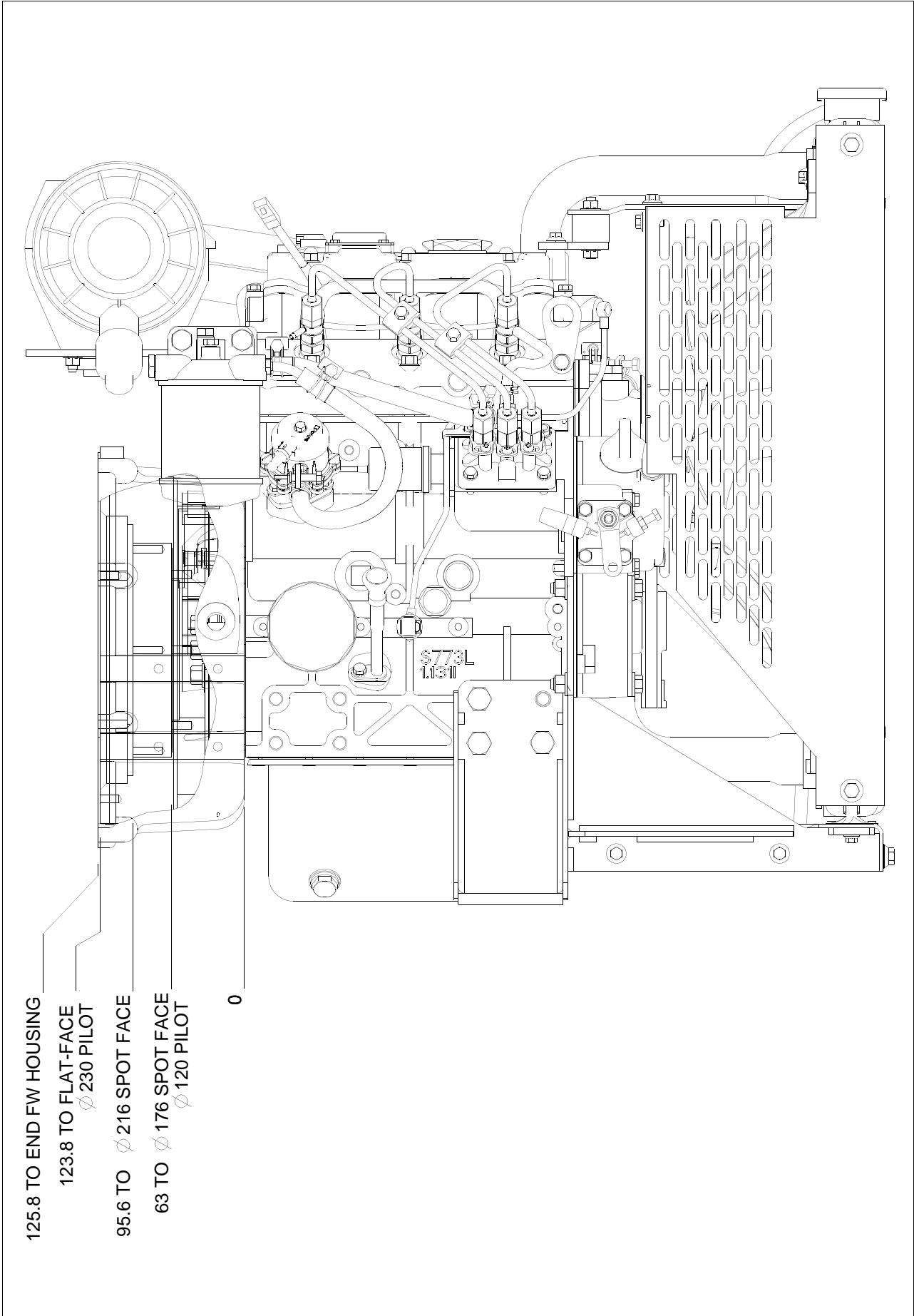

403A-11G1 ElectropaK, rear side view

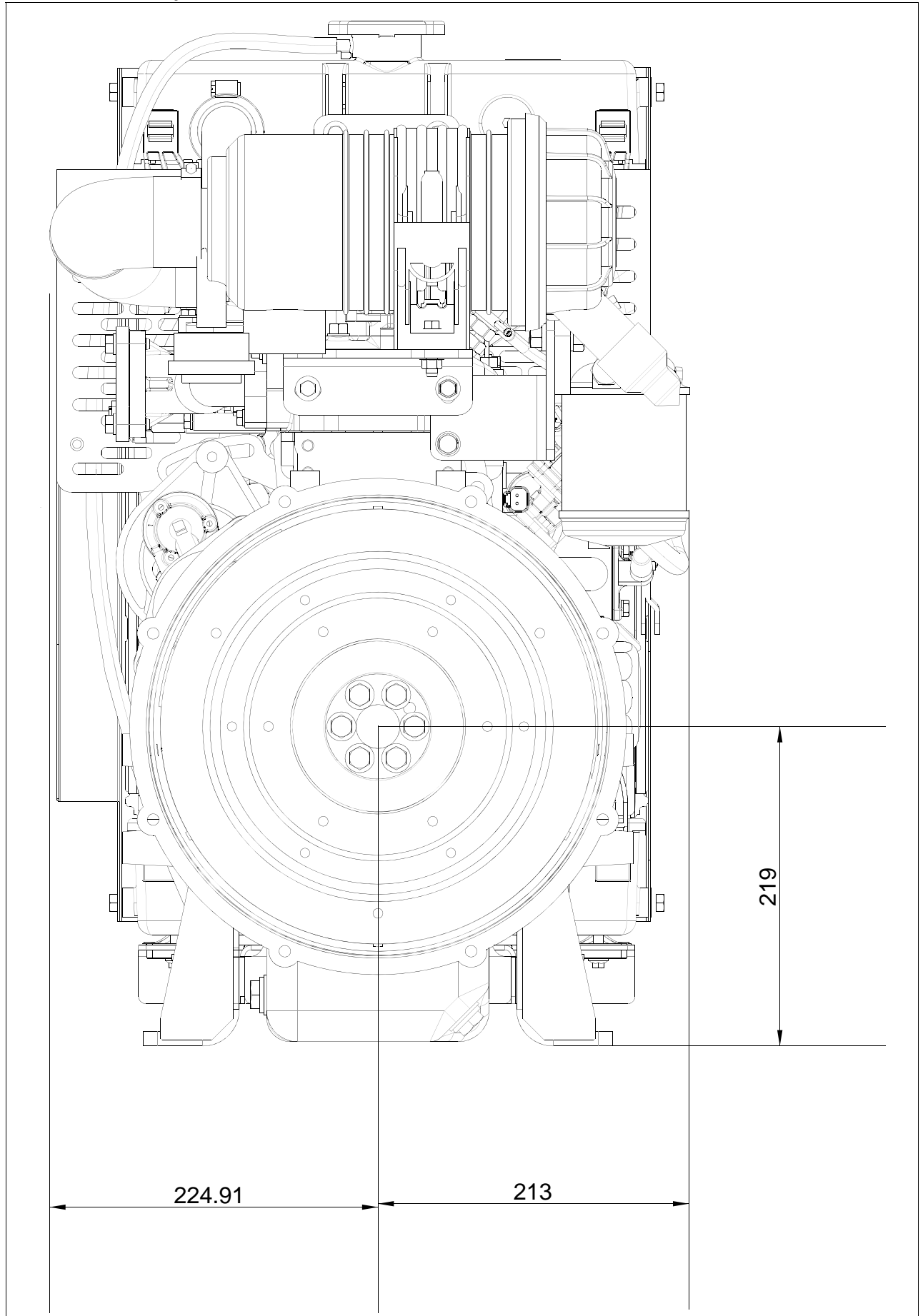

403A-11G1 ElectropaK, plan view

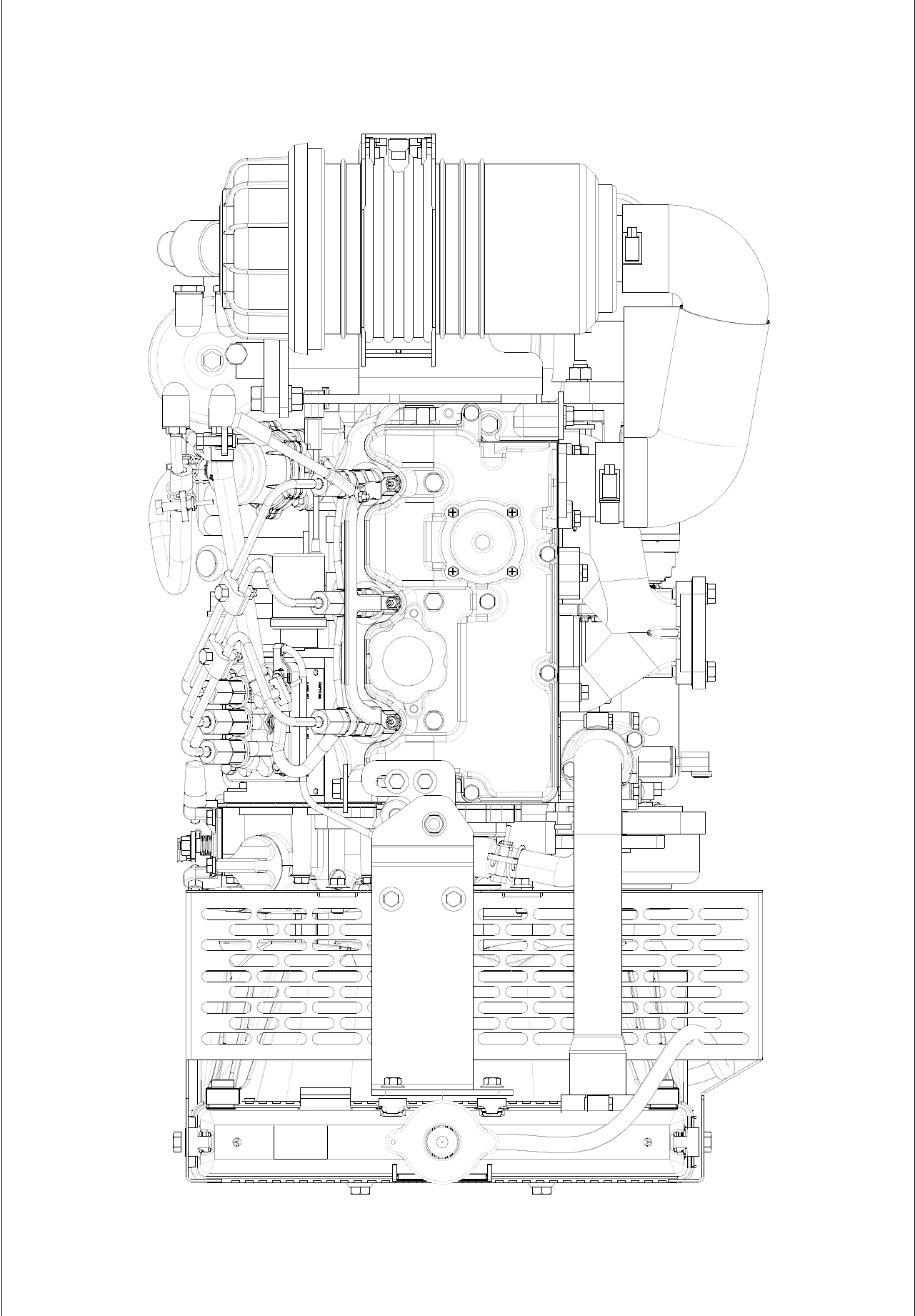

403A-11G1 ElectropaK, underneath view

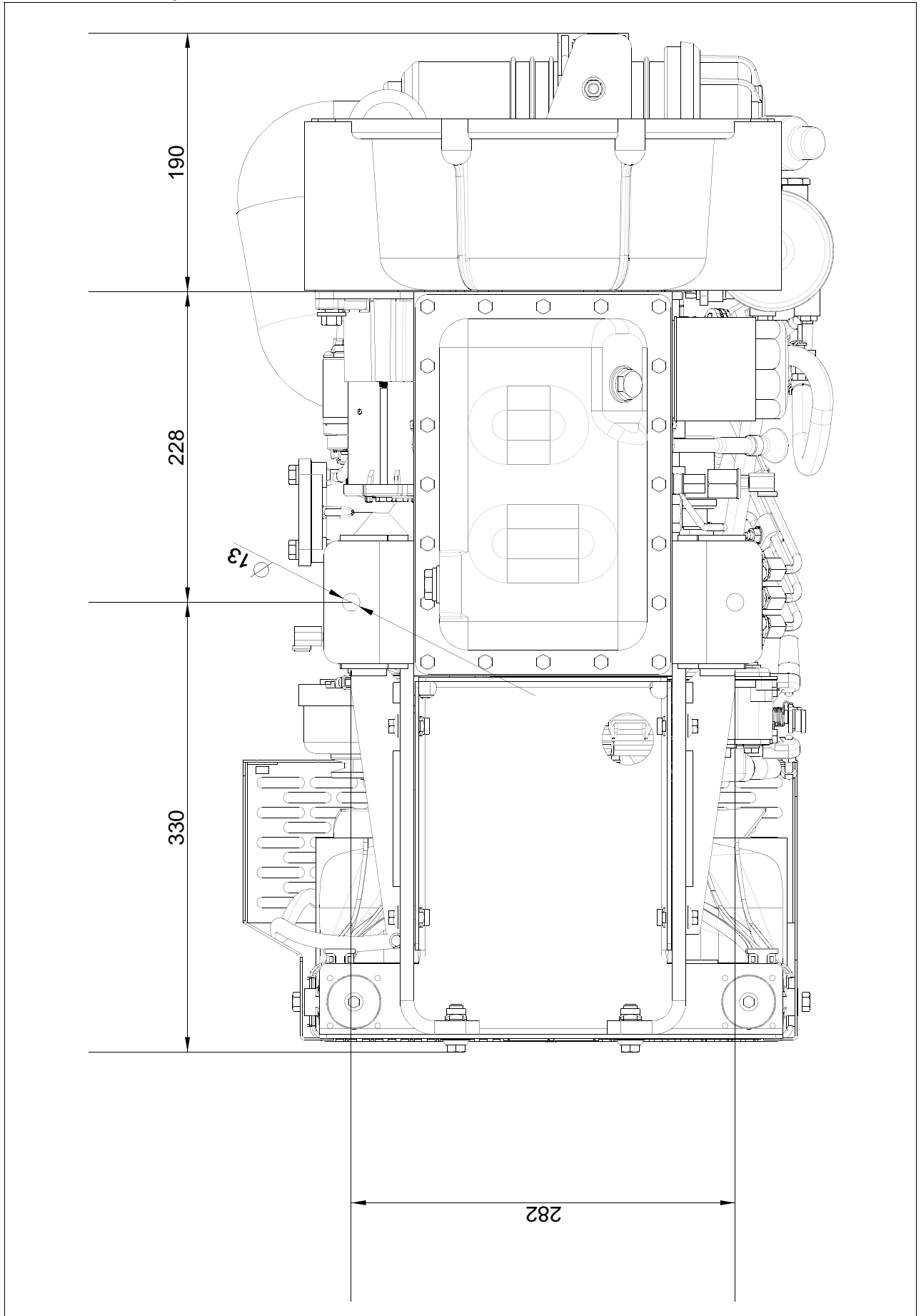

Cooling system

Radiator

-face area 0.147 m²
 -rows and materials 2 rows, Aluminium
 -matrix density and material 14.5 fins/inch Aluminium
 -width of matrix 334 mm
 -height of matrix 440 mm
 -pressure cap setting 90 kPa
 Estimated cooling air flow reserve 0.125 kPa

Fan

-diameter 320 mm
 -drive ratio 1.285:1
 -number of blades 6
 -material Plastic
 -type Pusher

Coolant

Total system capacity
 -with radiator 5.2 litres
 -without radiator 1.9 litres
 Maximum top tank temperature 112°C
 Max static pressure head on pump 30.4 kPa
 Temperature rise across engine TBA°C
 Max permissible external system resistance TBA kPa
 Thermostat operation range 75 - 87°C
 Recommended coolant: 50% anti freeze / 50% water. For complete details of recommended coolant specifications, refer to the Operation and Maintenance Manual for this engine model

Duct allowance

Maximum additional restriction (duct allowance) to cooling airflow and resultant minimum airflow		
Ambient clearance 50% Glycol	Duct allowance Pa	m ³ /sec
53°C	0	0.67
46°C	125	0.44

Electrical system

-alternator 15 amps, 12 V
 -starter motor 1.1 kW, 12 V

Cold start recommendations

Minimum cranking speed 150 rev/min

Minimum starting temperature °C	Grade of engine lubricating oil	Battery specifications			
		BS3911 Cold start amps	SAEJ537 Cold cranking amps	No. of batteries needed	Commercial ref number
0	20W	340	540	1	069
-15	10W	340	540	1	069
-20	5W	420	590	1	072

Note: Additional information for battery and cable limits can be found in Chapter 6 of the 400 Series Engine Sales Manual.

Exhaust system

Maximum back pressure 10.2 kPa
 Exhaust outlet size
 -horizontal 34 mm
 -vertical 40 mm

Fuel system

Type of injection Indirect injection
 Fuel injection pump Cassette type
 Fuel injector Pintle nozzle
 Nozzle opening pressure 14.7 MPa
 Maximum particle size 25 microns

Fuel lift pump

-type mechanical (camshaft driven)
 -flow/hour 63 litres/hr
 -pressure 10 kPa
 Maximum suction head 0.8 m
 Maximum static pressure head 3 m
 Governor type Mechanical

Fuel specification

USA Fed Off Highway - EPA2D 89.330-96

Europe Off Highway - CEC RF-06-99

Note: For further information on fuel specifications and restrictions, refer to the OMM Fuels section for this engine model

Fuel consumption

Power rating			
g/kWh (litres/hr)			
110%	100%	75%	50%
261 (2.9)	252 (2.6)	258 (2.0)	286 (1.5)

Induction system

Maximum air intake restriction

- clean filter. 3.0 kPa
- dirty filter ... 6.4 kPa
- air filter type ... Dry element type

Lubrication system

Lubricating oil capacity

- Maximum sump capacity... 4.4 litres
- Total system... 4.9 litres
- Minimum sump capacity ... 3.4 litres
- Maximum engine operating angles
- front up, front down, right side or left side ... 35° continuous

Lubricating oil pressure

- minimum oil pressure... 120 kPa
- relief valve opens.304 - 500 kPa
- at maximum no-load speed... TBA
- Normal oil temperature... 125°C
- oil flow at rated speed ... 6.6 litres/min.

Recommended SAE viscosity

A single or multi grade oil must be used which conforms API-CH-4 or ACEA E5.

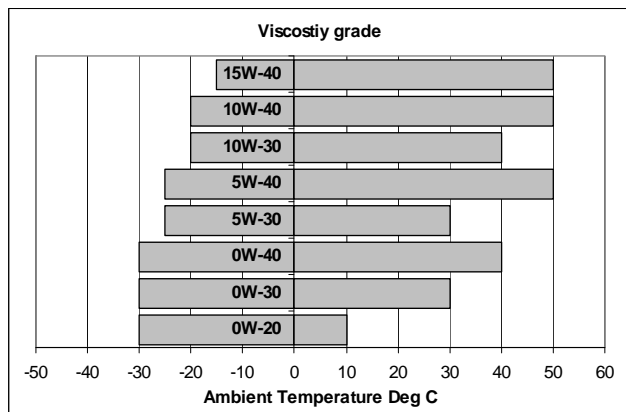

Maximum static bending moment

at rear face of block... 500 Nm

Load acceptance

The below complies with the requirements of classification 3 and 4 of ISO 8528-12 and G2 operating limits stated in ISO 8528-5

Initial load application: When engine reaches rated speed (15 seconds maximum after engine starts to crank)		
Descriptor	Units	50 Hz
% of prime power	%	TBA
Transient frequency deviation	%	TBA
Frequency recovery	Seconds	TBA

The above figures were obtained under the following test conditions:

- minimum engine block temperature... TBA°C
 - ambient temperature ... 25°C
 - governing mode ... 5 %
 - alternator inertia ... TBA kgm²
 - under frequency roll off (UFRO) point set to 2% Volt / 1% frequency
 - UFRO rate set to ... 1 Hz below rated speed
 - LAM on/off ... off
- All tests were conducted using an engine which was installed and serviced to Perkins Engines Company Limited recommendations.

Derate Curves

Derate curves for altitude and humidity can be found in Chapter 6 of the 400 Series Engine Sales Manual.

Note: The general arrangement drawings shown in this data sheet are for guidance only. For installation purposes, latest versions should be requested from the Applications Dept., Perkins Engines Stafford, ST16 3UB United Kingdom.

Notes



Perkins Engines Company Limited

Peterborough PE1 5NA United Kingdom

Telephone +44 (0) 1733 583000

Fax +44 (0) 1733 582240

www.perkins.com

All information in the document is substantially correct at the time of printing but may be subsequently altered by the company.

Distributed by