

Technical Data

4000 Series

Diesel Engine - Electropak

4006-23TAG2A

Used for 725kVA generator

4006-23TAG3A

Used for 800kVA generator

Basic technical data

Number of cylinders6
 Cylinder arrangement Vertical, In line
 Cycle 4 stroke, compression ignition
 Induction system Turbocharged
 Compression ratio 13.6:1 nominal
 Bore 160 mm
 Stroke 190 mm
 Cubic capacity 22,921 litres
 Direction of rotation Anti-clockwise viewed on flywheel
 Firing order 1, 5, 3, 6, 2, 4
 Cylinder 1 furthest from flywheel
 Total weight of Electrounit (engine only)
 -dry 2524 kg
 -wet 2663 kg

Overall dimensions

-height 1964 mm
 -length 3027 mm
 -width 1706 mm

Moment of inertia

Engine 4,59 kgm²
 Flywheel 6,02 kgm²
 Cyclic irregularity for engine/flywheel (prime power):

	TAG2A	TAG3A
1500 rev/min	1:67	1:62
1800 rev/min	1:105	1:97

Ratings

Steady state speed stability at constant load ± 0.25%
 Electrical ratings are based on average alternator efficiency and are for guidance only (0.8 power factor being used).

Operating point

Engine speed 1500/1800 rev/min
 Static injection timing See engine number plate
 Cooling water exit temperature 98 °C Max.
 Fuel data
 To conform to BS2869 class A2.

Performance

Estimated sound pressure level (Temperate):
 -1500 rev/min 106 dBA
 -1800 rev/min 111 dBA
 Estimated sound pressure level (Tropical):
 -1500 rev/min 107 dBA
Note: All data based on operation to ISO 3046/1, BS 5514 and DIN 6271 standard reference conditions.

For engines operating in ambient conditions other than the standard reference conditions stated below, a suitable de-rate must be applied. De-rate tables for increased ambient temperature and/or altitude are available, please contact Perkins Applications Department.

Test conditions

Air temperature 25 °C
 Barometric pressure 100 kPa
 Relative humidity 30%
 Air inlet restriction at maximum power (nominal) 2,5 kPa
 Exhaust back pressure (nominal) 3,0 kPa
 Fuel temperature (inlet pump) 58 °C maximum
 For test conditions relevant to data on load acceptance, refer to Perkins Applications Department.

General installation

4006-23TAG2A - Temperate

Designation	Units	50 Hz 1500 rev/min			60 Hz 1800 rev/min		
		Baseload power	Prime power	Standby power	Baseload power	Prime power	Standby power
Gross engine power	kWm	521	646	711	554	684	759
Fan power	kWm	22			38		
Net engine power	kWm	499	624	689	516	646	721
BMEP gross	kPa	1812	2247	2473	1606	1983	2200
Combustion air flow	m ³ /min	60	64	71	62	65	73
Exhaust gas temperature max. after turbo	°C	430					
Exhaust gas flow (max)	m ³ /min	180			190		
Boost pressure ration	-	3,0	3,4	3,6	3,2	3,4	3,6
Mechanical efficiency	%	90					
Overall thermal efficiency	%	43	42	41	41,5	41	40
Friction power and pumping losses	kWm	70			75		
Mean piston speed	m/s	9,5			11,4		
Engine coolant flow	l/s	10			12		
Cooling fan airflow	m ³ /min	1200			1320		
Typical Genset electrical output 0.8pf 25 °C (100 kPa)	kVA	592	740	817	612	766	855
	kWe	474	592	654	490	613	684
Assumed alternator efficiency	%	95			94		

General installation

4006-23TAG2A - Tropical

Designation	Units	50 Hz 1500 rev/min			60 Hz 1800 rev/min		
		Baseload power	Prime power	Standby power	Baseload power	Prime power	Standby power
Gross engine power	kWm	521	646	711	554	684	759
Fan power	kWm	26			44		
Net engine power	kWm	495	620	685	510	640	715
BMEP gross	kPa	1812	2247	2473	1606	1983	2200
Combustion air flow	m ³ /min	60	64	71	62	65	73
Exhaust gas temperature max. after turbo	°C	430					
Exhaust gas flow (max)	m ³ /min	180			190		
Boost pressure ration	-	3,0	3,4	3,6	3,2	3,4	3,6
Mechanical efficiency	%	90					
Overall thermal efficiency	%	43	42	41	41,5	41	40
Friction power and pumping losses	kWm	70			75		
Mean piston speed	m/s	9,5			11,4		
Engine coolant flow	l/s	10			12		
Cooling fan airflow	m ³ /min	1200			1320		
Typical Genset electrical output 0.8pf 25 °C (100 kPa)	kVA	585	730	800	600	750	844
	kWe	468	584	640	480	600	675
Assumed alternator efficiency	%	95			94		

4006-23TAG3A - Temperate

Designation	Units	50 Hz 1500 rev/min			60 Hz 1800 rev/min		
		Baseload power	Prime power	Standby power	Baseload power	Prime power	Standby power
Gross engine power	kWm	566	705	786	614	759	839
Fan power	kWm	22			38		
Net engine power	kWm	544	683	764	576	721	801
BMEP gross	kPa	1969	2452	2734	1780	2200	2432
Combustion air flow	m ³ /min	60	69	73	68	76	78
Exhaust gas temperature max. after turbo	°C	500					
Exhaust gas flow (max)	m ³ /min	193			209		
Boost pressure ration	-	3,1	3,5	3,8	3,35	3,6	3,79
Mechanical efficiency	%	90					
Overall thermal efficiency	%	43	41	40	41,5	40,5	39,5
Friction power and pumping losses	kWm	70			75		
Mean piston speed	m/s	9,5			11,4		
Engine coolant flow	l/s	10			12		
Cooling fan airflow	m ³ /min	1200			1320		
Typical Genset electrical output 0.8pf 25 °C (100 kPa)	kVA	645	810	906	683	855	950
	kWe	516	648	725	547	684	760
Assumed alternator efficiency	%	95			95		

General installation

4006-23TAG3A - Tropical

Designation	Units	50 Hz 1500 rev/min			60 Hz 1800 rev/min		
		Baseload power	Prime power	Standby power	Baseload power	Prime power	Standby power
Gross engine power	kWm	566	705	786	614	759	839
Fan power	kWm	26			44		
Net engine power	kWm	540	679	760	570	715	795
BMEP gross	kPa	1969	2452	2734	1780	2200	2432
Combustion air flow	m ³ /min	60	69	73	68	76	78
Exhaust gas temperature max. after turbo	°C	500					
Exhaust gas flow (max)	m ³ /min	193			209		
Boost pressure ration	-	3,1	3,5	3,8	3,35	3,6	3,79
Mechanical efficiency	%	90					
Overall thermal efficiency	%	43	41	40	41,5	40,5	39,5
Friction power and pumping losses	kWm	70			75		
Mean piston speed	m/s	9,5			11,4		
Engine coolant flow	l/s	10			12		
Cooling fan airflow	m ³ /min	1200			1320		
Typical Genset electrical output 0.8pf 25 °C (100 kPa)	kVA	640	800	900	675	844	938
	kWe	512	640	720	540	675	750
Assumed alternator efficiency	%	95			95		

Rating Definitions

Baseload power

Unlimited hours usage with an average load factor of 100% of the published Baseload Power. No overload is permitted on Baseload Power.

Prime power

Unlimited hours usage with an average load factor of 80% of the published Prime Power over each 24 hours period. A 10% overload is available for 1 hour in every 12 hours operation.

Standby power

Limited to 500 hours annual usage with an average load factor of 80% of the published Standby Power rating over each 24 hour period. Up to 300 hours of annual usage may be run continuously. No overload is permitted on Standby Power.

Energy balance

4006-23TAG2A - Temperate

Designation	Units	50 Hz 1500 rev/min ½ TA Luft			50 Hz 1500 rev/min Best SFC			1800 rev/min		
		Baseload power	Prime power	Standby power	Baseload power	Prime power	Standby power	Baseload power	Prime power	Standby power
Energy in fuel	kW	1365	1721	1880	1293	1595	1764	1457	1824	2033
Energy in power output (gross)	kW	521	646	711	521	646	711	554	684	759
Energy to cooling fan	kW	22			22			38		
Energy in power output (net)	kW	499	624	689	499	624	689	516	640	721
Energy to exhaust	kW	450	610	657	415	500	540	543	649	695
Energy to coolant and oil	kW	200	221	240	170	191	240	157	220	260
Energy to radiation	kW	40	55	76	52	64	71	58	73	81
Energy to charge coolers	kW	154	189	196	135	194	202	145	204	238

4006-23TAG2A - Tropical

Designation	Units	50 Hz 1500 rev/min ½ TA Luft			50 Hz 1500 rev/min Best SFC			1800 rev/min		
		Baseload power	Prime power	Standby power	Baseload power	Prime power	Standby power	Baseload power	Prime power	Standby power
Energy in fuel	kW	1365	1721	1880	1293	1595	1764	1457	1824	2033
Energy in power output (gross)	kW	521	646	711	521	646	711	554	684	759
Energy to cooling fan	kW	26			26			44		
Energy in power output (net)	kW	495	620	685	495	620	685	509	639	714
Energy to exhaust	kW	450	610	657	415	500	540	543	649	695
Energy to coolant and oil	kW	200	221	240	170	191	240	157	220	260
Energy to radiation	kW	40	55	76	52	64	71	58	73	81
Energy to charge coolers	kW	154	189	196	135	194	202	145	204	238

4006-23TAG3A - Temperate

Designation	Units	50 Hz 1500 rev/min ½ TA Luft			50 Hz 1500 rev/min Best SFC			1800 rev/min		
		Baseload power	Prime power	Standby power	Baseload power	Prime power	Standby power	Baseload power	Prime power	Standby power
Energy in fuel	kW	1470	1926	2154	1390	1749	1970	1598	1995	2258
Energy in power output (gross)	kW	566	705	786	566	705	786	614	759	839
Energy to cooling fan	kW	22			22			38		
Energy in power output (net)	kW	544	683	764	544	683	764	576	721	801
Energy to exhaust	kW	480	665	741	429	500	565	530	635	759
Energy to coolant and oil	kW	210	280	315	190	280	310	225	309	330
Energy to radiation	kW	59	77	86	56	70	79	64	80	90
Energy to charge coolers	kW	155	199	226	149	194	230	165	212	240

4006-23TAG3A - Tropical

Designation	Units	50 Hz 1500 rev/min ½ TA Luft			50 Hz 1500 rev/min Best SFC			1800 rev/min		
		Baseload power	Prime power	Standby power	Baseload power	Prime power	Standby power	Baseload power	Prime power	Standby power
Energy in fuel	kW	1470	1926	2154	1390	1749	1970	1598	1995	2258
Energy in power output (gross)	kW	566	705	786	566	705	786	614	759	839
Energy to cooling fan	kW	26			26			44		
Energy in power output (net)	kW	540	679	760	540	679	760	569	714	794
Energy to exhaust	kW	480	665	741	429	500	565	530	635	759
Energy to coolant and oil	kW	210	280	315	190	280	310	225	309	330
Energy to radiation	kW	59	77	86	56	70	79	64	80	90
Energy to charge coolers	kW	155	199	226	149	194	230	165	212	240

Note: ½ TA Luft figures have been developed to comply with ½ TA Luft as 1986 with 2000 mg/m³ NOx 5% O₂ limits for power generation engines.

Cooling system

Recommended coolant: 50% inhibited ethylene glycol or 50% inhibited propylene glycol and 50% clean fresh water. For combined heat and power systems and where there is no likelihood of ambient temperature below 10 °C, then clean 'soft' water may be used, treated with 1% by volume of Perkins inhibitor in the cooling system. The inhibitor is available in 1 litre bottles from Perkins.

Nominal jacket water pressure in crankcase. 170 kPa
 Maximum top temperature (standby) 98 °C
 Maximum static pressure head on pump 7 m
 Draw down capacity22 litres
 Maximum permissible restriction to coolant pump flow.20 kPa
 Thermostat operating range.. 71 - 85 °C
 Ambient cooling clearance (open ElectropaK prime power) based on air temp at fan 3 °C above ambient.

Temperate

Maximum additional restriction (duct allowance) to cooling airflow. (TAG2A and TAG3A standby power) and resultant minimum airflow					
Ambient clearance: 50% Glycol		Duct allowance mm H ₂ O		Min airflow m ³ /sec	
rev/min		rev/min		rev/min	
1500	1800	1500	1800	1500	1800
36 °C	39 °C	25	25	13	16

Tropical

Maximum additional restriction (duct allowance) to cooling airflow. (TAG2A and TAG3A standby power) and resultant minimum airflow					
Ambient clearance: inhibited coolant		Duct allowance mm H ₂ O		Min airflow m ³ /sec	
rev/min		rev/min		rev/min	
1500	1800	1500	1800	1500	1800
50 °C	50 °C	13	20	20	22

The above information at 1500 rev/min applies for ½ TA Luft and Best SFC ratings.

Radiator

Face area2,569 m²
 Rows and materials... .. 3 rows of brass tubes

Gills per inch and material

-jacket water... .. Copper fin at 14 gills/in
 -charge air section. Copper fin at 10 gills/in

Width and height of matrix

-height 1600 mm
 -width. 1606 mm
 Weight (dry) radiator 570 kg
 Total coolant capacity 105 litres
 Pressure cap setting 70 kPa

Coolant jacket data	Units	1500 rev/min	1800 rev/min
Coolant flow	l/s	10	12
Coolant exit temperature (max)	°C	98	98
Coolant entry temperature (min)	°C	70	70

Charge cooler, integral with radiator

Face area 1,622 m²

Coolant pump

Speed and method of drive... .. 1.4 x e rev/min Gear

Fan

Type Engine mounted
 Speed:
 -1500 1170 rev/min
 -1800 1404 rev/min
 Diameter. 1,2 m
 Number of blades:
 -Temperate. 6
 -Tropical 8
 Material... .. Steel
 Drive ratio 0.78:1

Lubrication system

Recommended lubricating oil to conform with the specification of API CG4 15W/40

Lubricating oil capacity

-sump maximum 113,4 litres
 -sump minimum... .. 90,7 litres

Lubrication oil pressure at rated speed

Minimum. 240 kPa
 Oil relief valves open 300 kPa
 Oil filter spacing 40 microns
 Sump drain plug tapping size G1
 Oil pump speed and method of drive 1.4 x e rev/min, gear

Oil pump flow

-1500 rev/min 3,7 litres/sec
 -1800 rev/min 4,4 litres/sec
 Oil consumption as a percentage of full load fuel consumption less than 0.25%

Normal operating angles

Front and rear. 5°
 Side tilt 10°

Electrical system

Type Insulated return
 Alternator 40 amps at 28 volts, stabilised output at 20 °C ambient
 Starter motor 7,5 kW
 Number of teeth on flywheel... .. 190
 Number of teeth on starter motor 12
 Minimum cranking speed 120 rev/min
 Pull in current of starter motor solenoid 30 amps at 24 volts
 Hold in current of starter motor solenoid 9 amps at 24 volts
 Engine stop solenoid 24 volts
 Pull in current of stop solenoid 60 amps at 24 volts

Starting requirements

Temperature range	
To 10 °C (50 °F)	Oil: CG4 15w/40
	Starter: 1 x 24 volts
	Battery: 2 x 12v x Ah 143
	max. breakaway:
	-current 1000 amps
-cranking current 600 amps	
-aids Not necessary	

Notes:

- The battery capacity is defined by the 20 hour rate at 0 °C
- The oil specification should be for the minimum ambient temperature as the oil will not be warmed by the immersion heater
- The breakaway current is dependant on the battery capacity available. Cables should be capable of handling the transient current which may be up to double the steady cranking current.

Fuel system

Recommended fuel ... To conform to BS2869 1998 Class A1, A2
 Type of injection system ... Direct injection
 Fuel injector ... Combined unit injector
 Fuel injector pressure
 ... 220 ATS (NOP) 1400 bar maximum operating pressure

Delivery

-1500 rev/min ... 660 litres/hour
 -1800 rev/min ... 810 litres/hour
 Fuel delivery pump pressure... 300 kPa
 Fuel lift pump maximum suction head ... 2.5 m
 Fuel return maximum pressure head
 ... 3m above fuel delivery pump
 Fuel filter spacing... 10 microns
 Governor type ... Electronic

Fuel consumption gross (½ TA Luft)

Temperate and Tropical

	g/kWh		l/h	
	1500	1800	1500	1800
4006-23TAG2A				
Standby	213	226	176	200
Prime	213	221	159	176
Baseload	205	210	127	135
75% Prime	210	212	119	129
50% Prime	208	212	79	90
4006-23TAG3A				
Standby	222	230	203	224
Prime	214	226	175	200
Baseload	207	213	139	152
75% Prime	213	214	132	145
50% Prime	213	205	88	96

Fuel consumption gross (Best SFC)

Temperate and Tropical

	g/kWh		l/h	
	1500	1800	1500	1800
4006-23TAG2A				
Standby	210	226	173	199
Prime	209	222	157	177
Baseload	210	210	127	136
75% Prime	211	212	121	129
50% Prime	213	212	83	90
4006-23TAG3A				
Standby	212	230	194	224
Prime	210	226	172	200
Baseload	208	213	137	152
75% Prime	210	214	130	144
50% Prime	213	205	90	96

Induction system

Maximum air intake restriction of engine

-clean filter ... 127 mm H₂O
 -dirty filter ... 380 mm H₂O
 -air filter type ... dry - paper

Exhaust system

Exhaust outlet size (internal) ... 2 x 152,4 mm

Exhaust back pressure for total system

-TAG2A ... 610 mm H₂O
 -TAG3A ... 610 mm H₂O
 For recommended pipe sizes see the Installation Manual.

Engine mounting

Maximum additional load applies to flywheel due to all rotating components ... 650 kg
 Position of engine centre of gravity (wet):
 -forward of the rear face of the crankcase... 625 mm
 -above the crankshaft centre line ... 140 mm

4006-23TAG2A and 4006-23TAG3A - Left hand side view

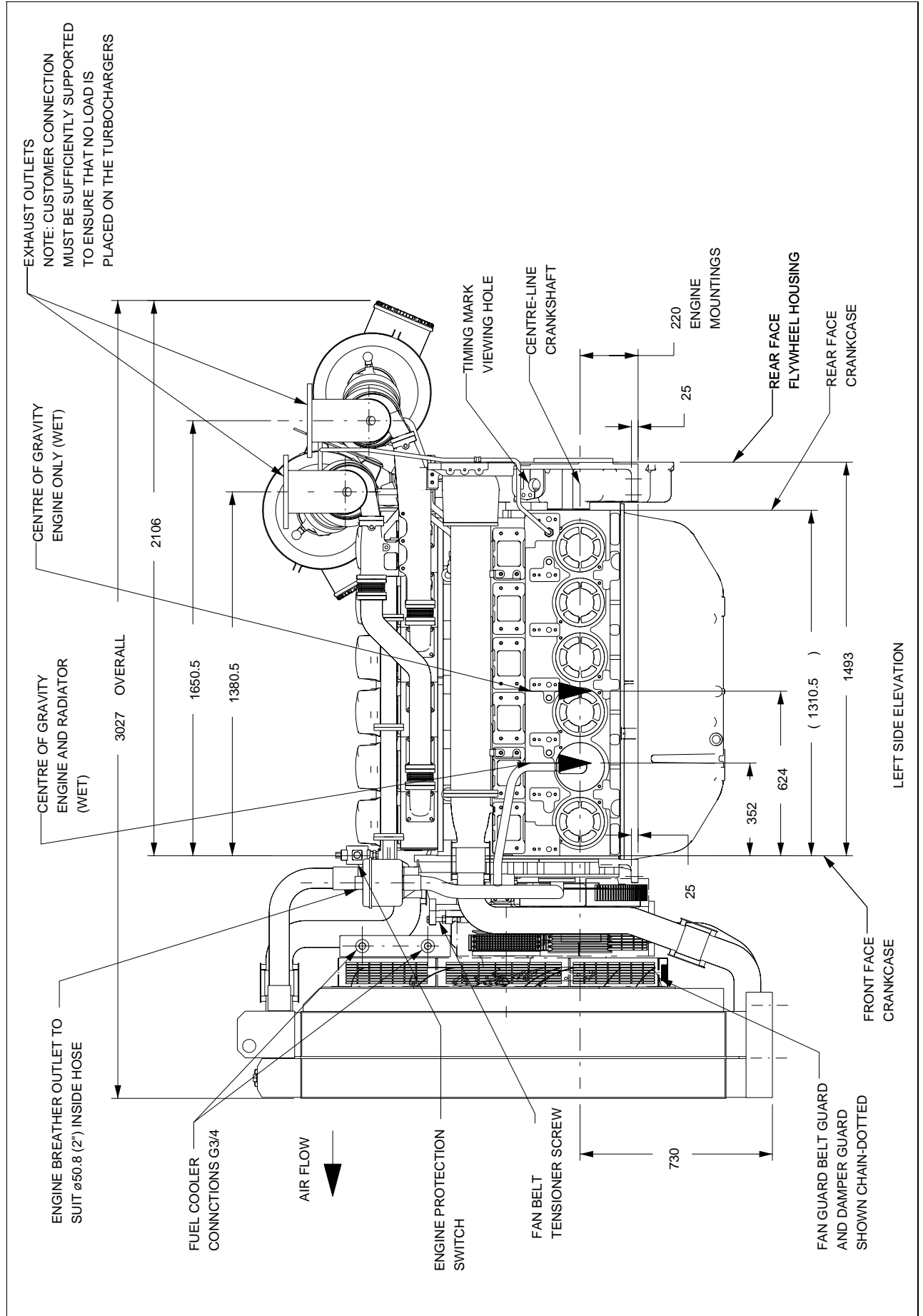

4006-23TAG2A and 4006-23TAG3A - Front view

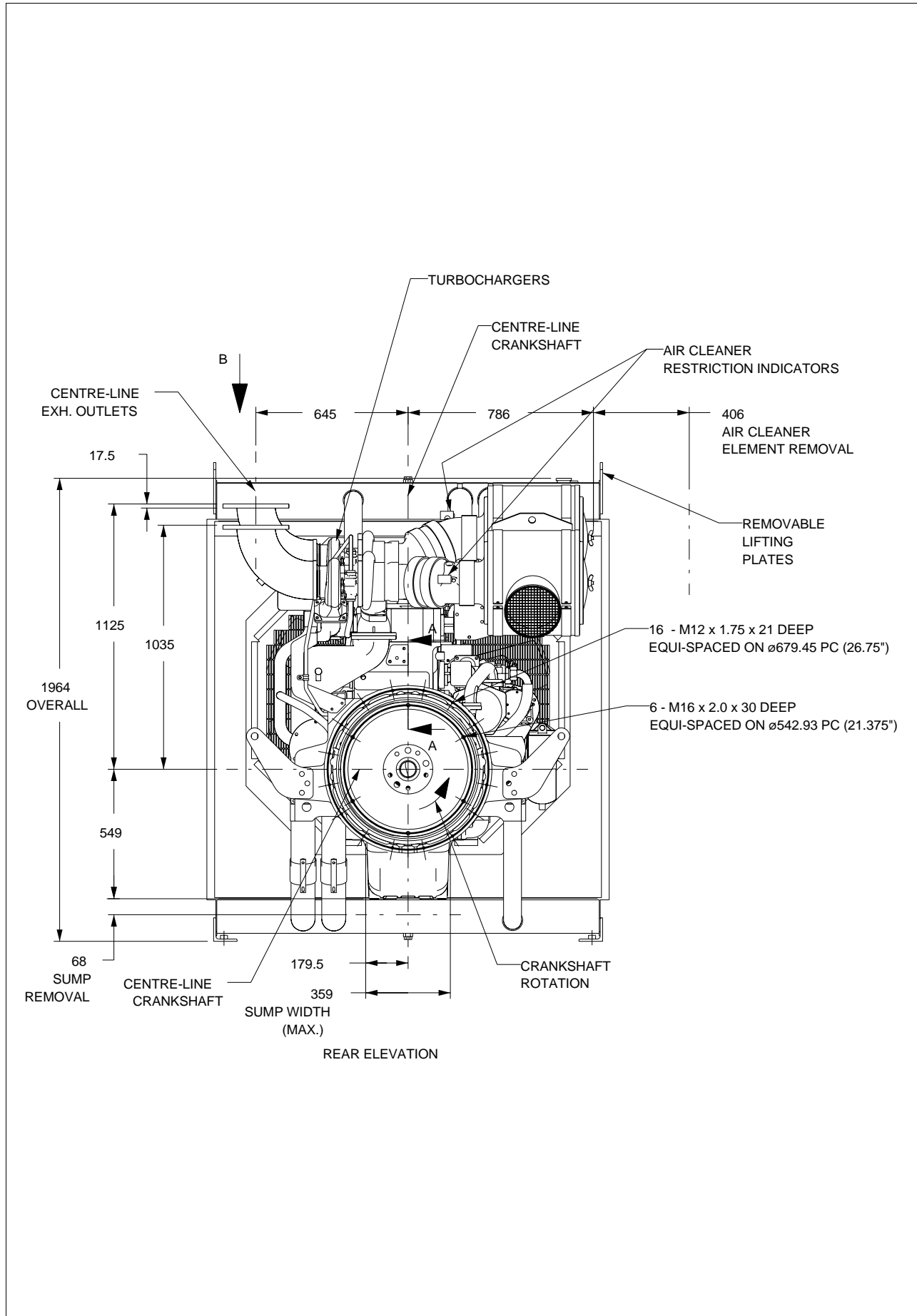

4006-23TAG2A and 4006-23TAG3A - Right hand side view

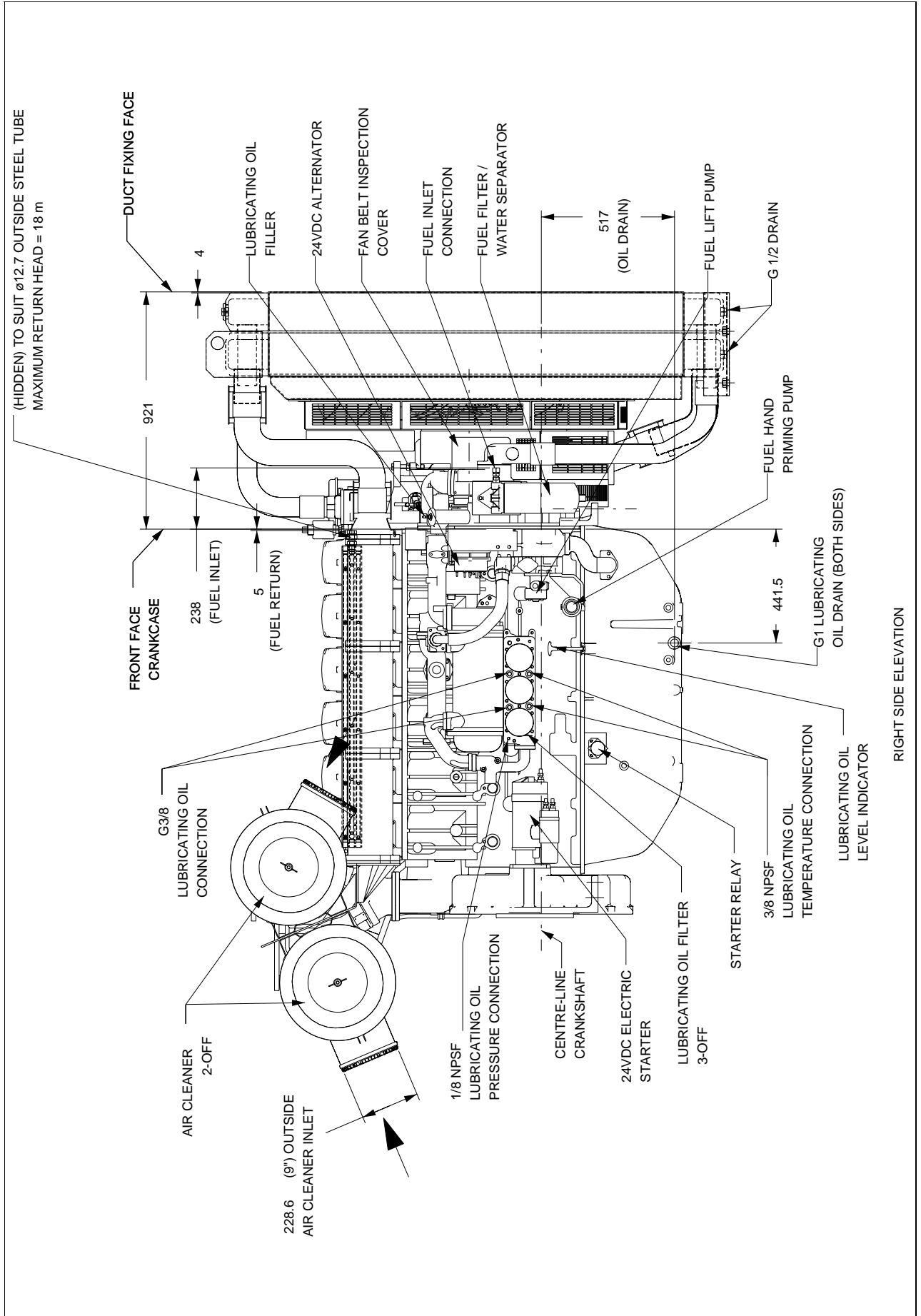

4006-23TAG2A and 4006-23TAG3A - Rear view

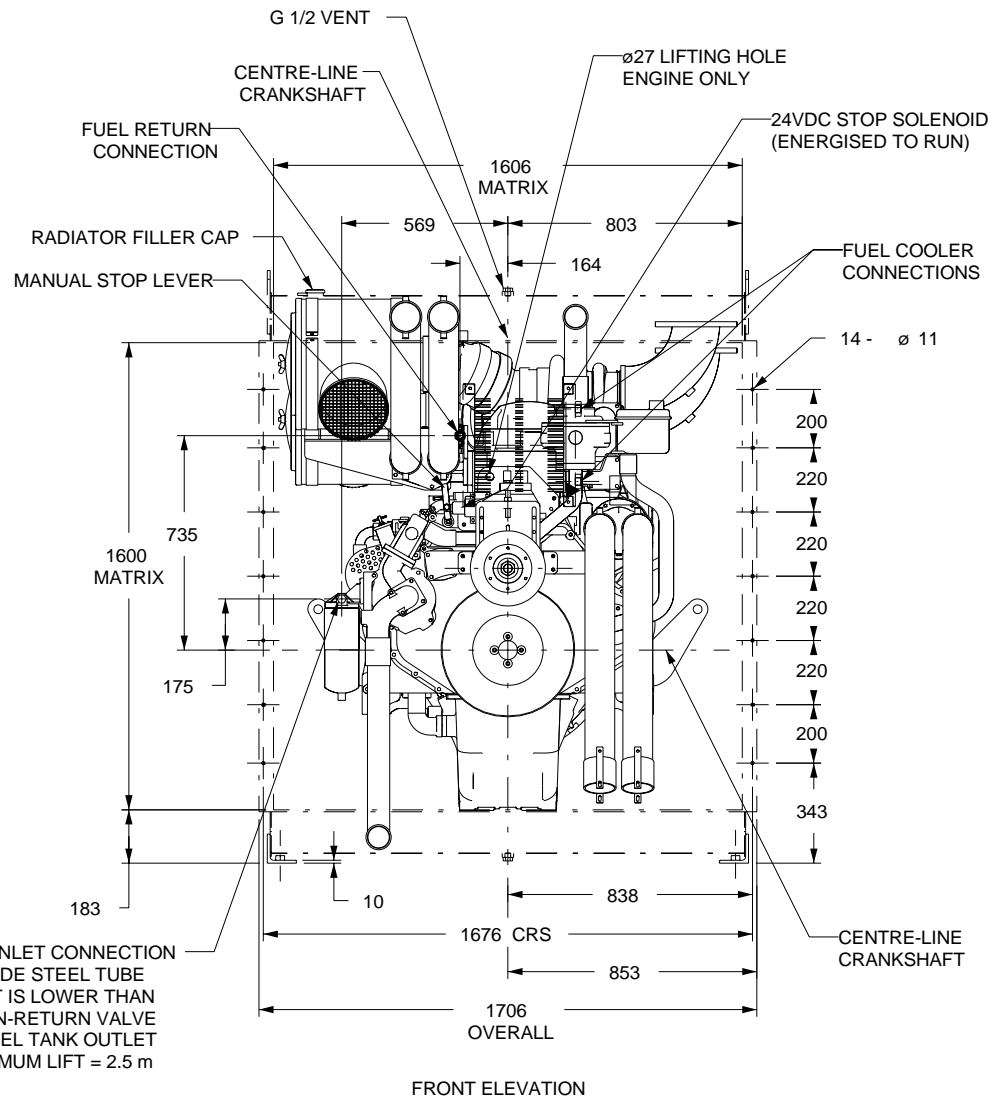

Typical Load Acceptance (cold)

At 1500 rev/min

Engine type	Initial Load Acceptance When engine reaches rated speed (15 seconds maximum after engine starts to crank)				2nd Load Application Immediately after engine has recovered to rated speed (5 seconds after initial load application)			
	Prime Power %	Load kWm (kWe) Net	Transient Frequency Deviation %	Frequency recovery time seconds	Prime Power %	Load kWm (kWe) Net	Transient Frequency Deviation %	Frequency recovery time seconds
4006-23TAG2A	69	426 (400)	≤ -10	5	31	194 (184)	≤ -10	5
4006-23TAG3A	66	448 (421)	≤ -10	5	34	231 (219)	≤ -10	5

At 1800 rev/min

Engine type	Initial Load Acceptance When engine reaches rated speed (15 seconds maximum after engine starts to crank)				2nd Load Application Immediately after engine has recovered to rated speed (5 seconds after initial load application)			
	Prime Power %	Load kWm (kWe) Net	Transient Frequency Deviation %	Frequency recovery time seconds	Prime Power %	Load kWm (kWe) Net	Transient Frequency Deviation %	Frequency recovery time seconds
4006-23TAG2A	70	447 (412)	≤ -10	5	30	193 (180)	≤ -10	5
4006-23TAG3A	67	483 (454)	≤ -10	5	33	232 (221)	≤ -10	5

The above complies with requirements of Classification 3 & 4 of ISO 8528 - 12 and G2 operating limits stated in ISO 8528 - 5.

The above figures were obtained under test conditions as follows:

Engine block temperature 45 °C

Alternator efficiency 94%

Minimum ambient temperature 10 °C

Isochronous governing

Under frequency roll off (UFRO) set to 1 Hz below rated frequency

Typical alternator inertia 20 kgm²

All tests were conducted using an engine installed and serviced to Perkins Engines Company Limited recommendations.

The information given on this Technical Data Sheet is for standard engines, and for guidance only. For ratings other than shown contact the Applications department.

Noise levels

The figures for total noise levels are typical for an engine running at Prime Power rating in a semi-reverberant environment and measured at a distance of one metre from the periphery of the engine.

Octave analysis

The following histograms show an octave band analysis at the position of the maximum noise level.

Total noise level

Sound pressure level

re: -20×10^{-6} pa

Speed 1500 rev/min ... Ambient noise level 79 dBA 4006TAG2A/3A

Octave analysis performed at the position of maximum noise.

4006TAG2A/3A - Temperate

POSITION 1

1500 rev/min	104,0 - dBA	4006TAG2A
1800 rev/min	109,0 - dBA	4006TAG2A
1500 rev/min	104,0 - dBA	4006TAG3A
1800 rev/min	109,0 - dBA	4006TAG3A

POSITION 7

1500 rev/min	105,5 - dBA	4006TAG2A
1800 rev/min	107,5 - dBA	4006TAG2A
1500 rev/min	106,0 - dBA	4006TAG3A
1800 rev/min	108,0 - dBA	4006TAG3A

POSITION 6

1500 rev/min	107,5 - dBA	4006TAG2A
1800 rev/min	109,0 - dBA	4006TAG2A
1500 rev/min	108,0 - dBA	4006TAG3A
1800 rev/min	110,0 - dBA	4006TAG3A

POSITION 5

1500 rev/min	106,5 - dBA	4006TAG2A
1800 rev/min	107,5 - dBA	4006TAG2A
1500 rev/min	107,0 - dBA	4006TAG3A
1800 rev/min	108,0 - dBA	4006TAG3A

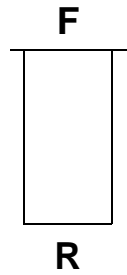

POSITION 2

1500 rev/min	105,5 - dBA	4006TAG2A
1800 rev/min	108,5 - dBA	4006TAG2A
1500 rev/min	106,0 - dBA	4006TAG3A
1800 rev/min	109,0 - dBA	4006TAG3A

POSITION 3

1500 rev/min	108,5 - dBA	4006TAG2A
1800 rev/min	110,0 - dBA	4006TAG2A
1500 rev/min	109,0 - dBA	4006TAG3A
1800 rev/min	110,0 - dBA	4006TAG3A

POSITION 4

1500 rev/min	107,0 - dBA	4006TAG2A
1800 rev/min	107,5 - dBA	4006TAG2A
1500 rev/min	107,5 - dBA	4006TAG3A
1800 rev/min	108,0 - dBA	4006TAG3A

4006TAG2A

1500 rev/min at position 7

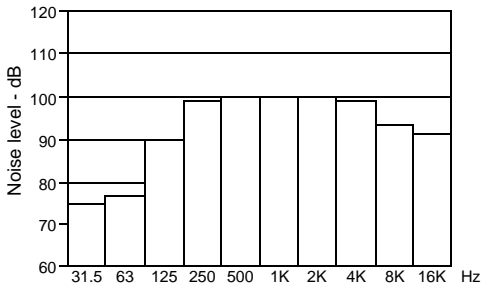

4006TAG3A

1500 rev/min at position 7

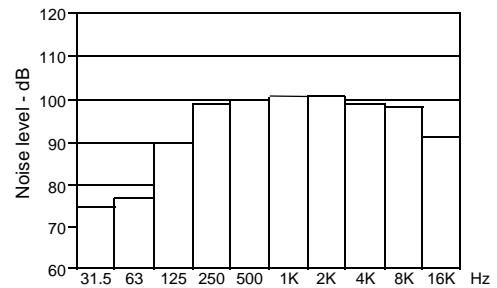

4006TAG2A

1800 rev/min at position 7

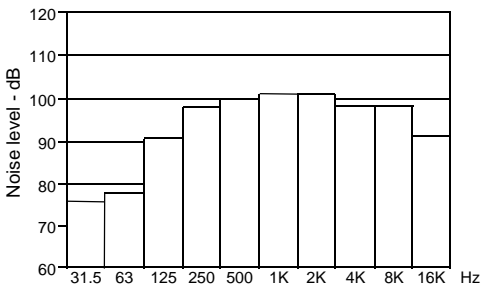

4006TAG3A

1800 rev/min at position 7

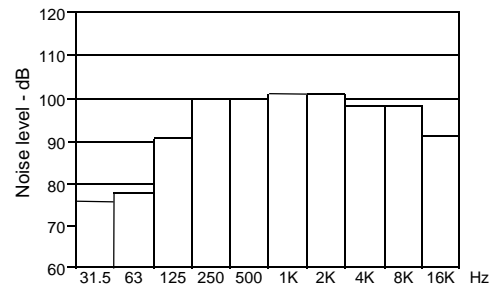

4006TAG2A/3A - Tropical

POSITION 1

1500 rev/min	108,0 - dBA	4006TAG2A
1800 rev/min	111,0 - dBA	4006TAG2A
1500 rev/min	108,0 - dBA	4006TAG3A
1800 rev/min	111,0 - dBA	4006TAG3A

POSITION 7

1500 rev/min	106,5 - dBA	4006TAG2A
1800 rev/min	108,0 - dBA	4006TAG2A
1500 rev/min	107,0 - dBA	4006TAG3A
1800 rev/min	109,0 - dBA	4006TAG3A

POSITION 6

1500 rev/min	106,5 - dBA	4006TAG2A
1800 rev/min	110,0 - dBA	4006TAG2A
1500 rev/min	107,0 - dBA	4006TAG3A
1800 rev/min	110,0 - dBA	4006TAG3A

POSITION 5

1500 rev/min	107,0 - dBA	4006TAG2A
1800 rev/min	109,5 - dBA	4006TAG2A
1500 rev/min	107,0 - dBA	4006TAG3A
1800 rev/min	111,0 - dBA	4006TAG3A

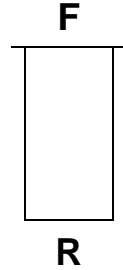

POSITION 2

1500 rev/min	106,0 - dBA	4006TAG2A
1800 rev/min	109,0 - dBA	4006TAG2A
1500 rev/min	106,0 - dBA	4006TAG3A
1800 rev/min	110,0 - dBA	4006TAG3A

POSITION 3

1500 rev/min	108,0 - dBA	4006TAG2A
1800 rev/min	111,0 - dBA	4006TAG2A
1500 rev/min	108,0 - dBA	4006TAG3A
1800 rev/min	112,0 - dBA	4006TAG3A

POSITION 4

1500 rev/min	106,0 - dBA	4006TAG2A
1800 rev/min	108,0 - dBA	4006TAG2A
1500 rev/min	106,0 - dBA	4006TAG3A
1800 rev/min	109,0 - dBA	4006TAG3A

4006TAG2A

1500 rev/min at position 7

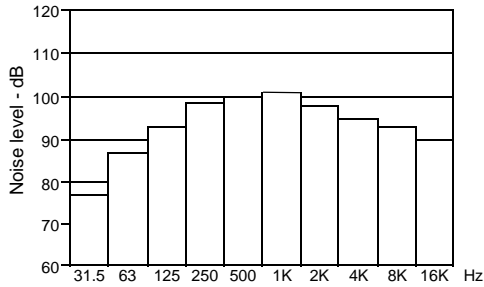

4006TAG3A

1500 rev/min at position 7

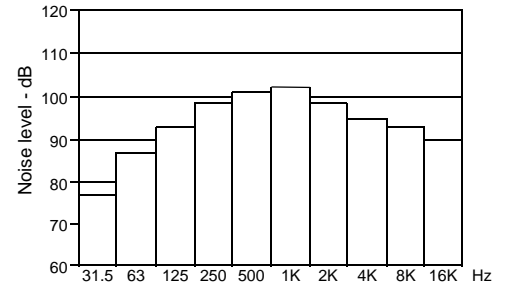

4006TAG2A

1800 rev/min at position 7

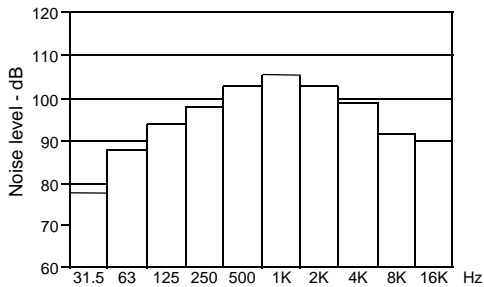

4006TAG3A

1800 rev/min at position 7

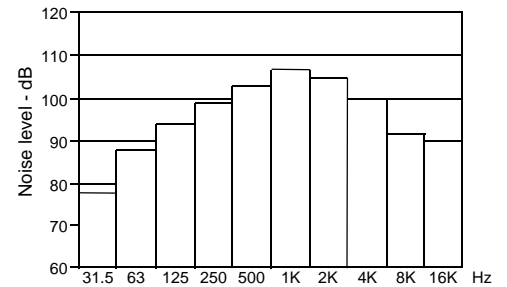

The information given on this Technical Data Sheet are for standard ratings only. For ratings other than those shown, please contact Perkins Engines Company Limited, Stafford.

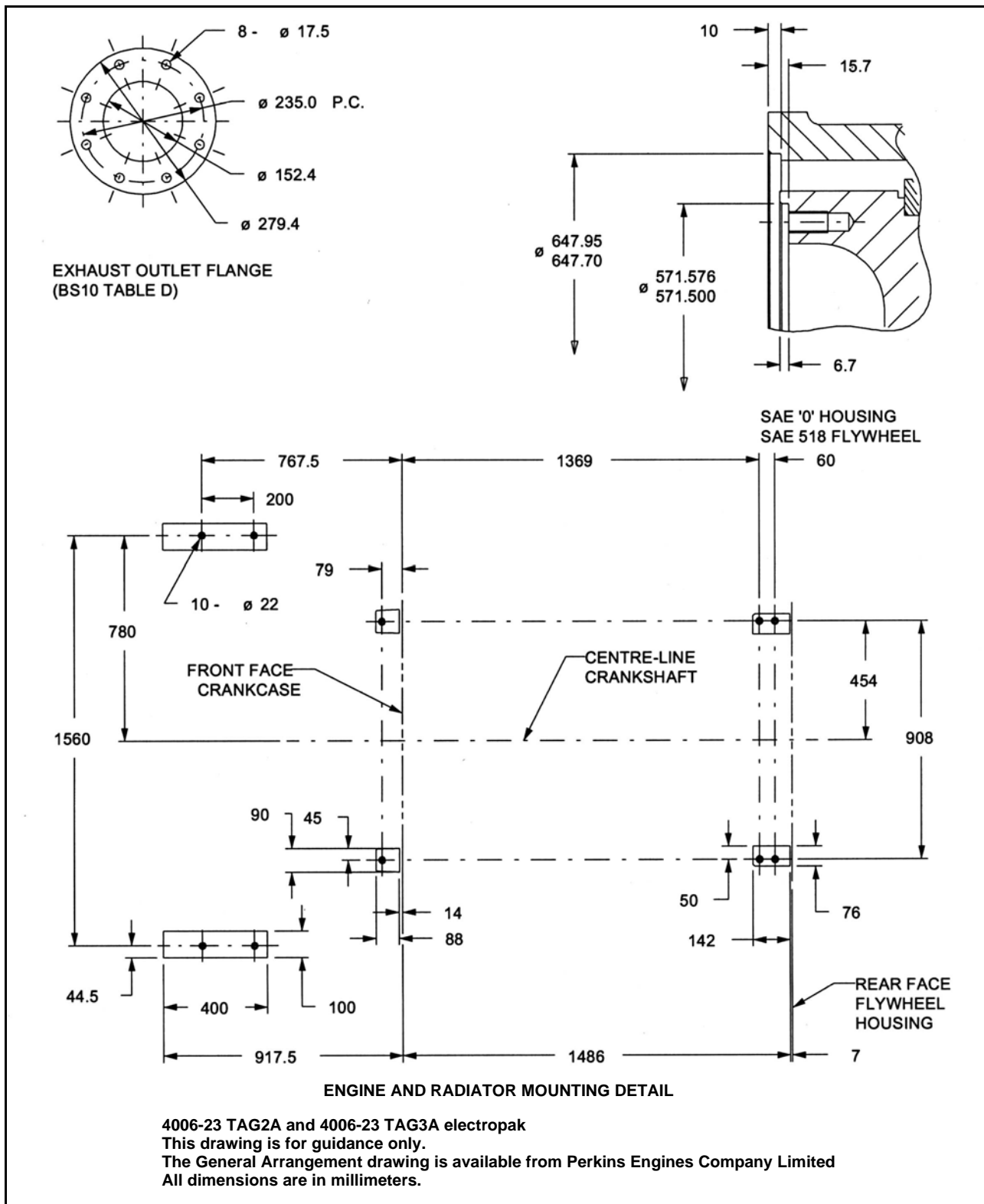

@ Perkins®

Perkins Engines Company Limited
 Peterborough PE1 5NA United Kingdom
 Telephone +44 (0) 1733 583000
 Fax +44 (0) 1733 582240
 www.perkins.com

Distributed by

All information in the document is substantially correct at the time of printing but may be subsequently altered by the company.