

1103A-33TG2

Used for 60kVA generator

1100

Series

59.3 kWm @ 1500 rpm
67.4 kWm @ 1800 rpm

Basic technical data

Number of cylinders 3
Cylinder arrangement Vertical in-line
Cycle Four stroke
Induction system Turbocharged
Compression ratio 17.25 : 1
Bore 105 mm (4.13 in)
Stroke 127 mm (4.99 in)
Cubic capacity 3.3 litres
Direction of rotation Clockwise view from front
Firing order 1,2,3

Weight of Genset (engine only)

Dry 420 kg
Wet 438 kg

Overall dimensions

Height 951 mm (37.44 inches)
Length 1049 mm (41.29 inches)
Width (including mounting brackets) 634 mm (24.96 inches)

Moment of inertia

Engine:
- longitudinal 25 kgm²
- horizontal 42 kgm²
- axial 25 kgm²
Flywheel (polar) 1.14 kgm²

Centre of gravity (wet)

Forward from rear of block 215 mm (8.46 inches)
Above centre line of block 120 mm (4.72 inches)
Offset of RHS of centre line 25 mm (0.98 inches)

Performance

Steady state speed stability at constant load: G2 ± 0.75%

Note: All data based on operation to ISO 3046/1, BS 5514 and DIN 6271 standard reference conditions.

Test conditions

Air temperature 25°C
Barometric pressure 100 kPa
Relative humidity 30%

Sound Level

Overall sound pressure level (cooling pack and air cleaner fitted):

@1500 rpm 89.4 dB(A)
@1800 rpm 92.8 dB(A)

Note: Sound pressure level from the mean of 4 microphones at the front, left, right and above the engine. Exhaust was piped away out of the test cell.

Note: If the engine is to operate in ambient conditions other than those of the test conditions, suitable adjustments must be made for these changes. For full details, contact Perkins Technical Service Department.

Cyclic irregularity (for engine & flywheel)

Prime Power:

@1500 rpm ±0.055%
@1800 rpm ±0.037%

General installation

1103A-33TG2

Designation	Units	Type of operation and application			
		Prime power 50 Hz	Standby power 50 Hz	Prime power 60 Hz	Standby power 60 Hz
Gross engine power	kWm	55.0	60.5	63.3	69.6
Brake mean effective pressure	kPa (lbf/in ²)	1333 (193.3)	1467 (212.7)	1279 (185.5)	1406 (203.9)
Mean piston speed	m/s (ft/s)	6.35 (20.8)		7.62 (25.0)	
ElectropaK nett engine power	kWm	53.8	59.3	61.2	67.5
Engine coolant flow 35 kPa restriction	litres/min (UK gal/min)	125.5 (27.6)		151.0 (33.2)	
Combustion air flow	m ³ /min (ft ³ /min)	3.8 (134.1)	3.9 (137.7)	4.7 (165.9)	4.9 (173.0)
Exhaust gas flow (max.)	m ³ /min (ft ³ /min)	10.1 (356.6)	10.4 (367.2)	11.8 (416.7)	12.5 (441.4)
Exhaust gas temperature (max.) in manifold	°C (°F)	557 (1034.6)	571 (1059.8)	534 (993.2)	564 (1047.2)
Cooling fan air flow	m ³ /min (ft ³ /min)	89.0 (3134.0)		111.0 (3919.9)	
Overall thermal efficiency (nett)	%	39.2	39.0	37.9	38.7
Typical Genset electrical output (0.8pf 25°C)	kWe	48.0	52.8	54.5	60.1
	kVA	60.0	66.0	68.1	75.1
Assumed alternator efficiency	%	89			

Energy balance

Designation	Units	Prime power 50 Hz	Standby power 50 Hz	Prime power 60 Hz	Standby power 60 Hz
Power in fuel (Fuel heat of combustion)	kW (Btu/min)	140.0 (7968.7)	155.0 (8822.5)	167.0 (9509.5)	177.0 (10074.7)
Power output (gross)	kW (Btu/min)	55.0 (3130.5)	60.5 (3443.6)	63.3 (3603.0)	68.5 (3898.9)
Power to cooling fan	kW (Btu/min)	1.2 (68.3)		2.1 (119.5)	
Power output (nett)	kW (Btu/min)	53.8 (3062.2)	59.3 (3375.3)	61.2 (3483.4)	66.4 (3779.4)
Power to coolant and lubricating oil	kW (Btu/min)	35.0 (1992.1)	38.0 (2162.9)	41.0 (2333.7)	43.0 (2447.5)
Power to exhaust	kW (Btu/min)	41.0 (2333.7)	46.0 (2618.3)	52.0 (2959.8)	54.0 (3073.6)
Power to radiation	kW (Btu/min)	10.0 (569.1)	11.0 (626.1)	11.0 (626.1)	

Note: The airflows shown in this table will provide acceptable cooling for an open power unit operating in ambient temperatures of up to 53 °C (127 °F) or 46 °C (114.8 °F) if a canopy is fitted. If the power unit is to be enclosed totally, a cooling test should be done to check that the engine cooling is acceptable. If there is insufficient cooling, contact Perkins Technical Service Department.

Cooling system

Radiator

Face area 0.276 m² (2.97 ft²)
 Rows and materials..... Single row aluminium
 Matrix density and material Aluminium 12,5 fins/inch
 Width of matrix..... 526 mm (20.7 inches)
 Height of matrix 524 mm (20.6 inches)
 Pressure cap setting 107 kPa

Fan

Diameter 457mm (18 in)
 Drive ratio 1.25:1
 Number of blades 7
 Material Composite
 Type Pusher

Coolant

Recommended coolant: 50 % ethylene glycol with a corrosion inhibitor (BS 658 : 1992 or MOD AL39) and 50% clean fresh water.

Total system capacity:
 With radiator 10.2 l (21.5 pt)
 Without radiator 4.4 l (9.2 pt)
 Maximum top tank temperature 110 °C (230 °F)
 Thermostat operating range..... 82 - 93 °C (180 - 199 °F)

Lubrication system

Lubricating oil capacity

Total system 8.3 litres (17.5 pt)
 Sump minimum 6.2 litres (13.1 pt)
 Sump maximum 7.8 litres (16.4 pt)
 Maximum engine operating angles:
 Front up, front down, right side or left side 25°

Lubricating oil pressure

Relief valve opens 415 - 470 kPa
 - at maximum no-load speed..... 276 - 414 kPa
 Max continuous oil temperature (in rail) 125 °C (257 °F)
 Oil consumption at full load as a % of fuel consumption 0.15%

Exhaust system

Maximum back pressure
 1500 rpm 10 kPa
 1800 rpm 15 kPa
 Exhaust outlet size 56 mm (2.2 inches)

Fuel System

Type of injection Direct
 Fuel injection pump Rotary
 Fuel atomiser..... Multi-hole
 Nozzle opening pressure 29 MPa (290 bar)

Fuel lift pump

Type Mechanical
 Flow/hour 120 - 150 litres/h (211 - 264 pt/m)
 Pressure 30 - 75 kPa (4.4 - 10.9 psi)
 Maximum suction head:
 1500 rpm 20 kPa

Governor type

Mechanical speed control to ISO 8528, G2

Fuel specification

Fuel Specification	European RF75-T-96 / DIN EN590 / BS2869 class A2
Density (kg/l @ 15 °C)	0.835 - 0.845
Viscosity (mm ² /s @ 40 °C)	2.5 - 3.5
Sulphur content (%)	0.1 - 0.2
Cetane number	45 - 50

Fuel consumption litres/hour (UK gals/hr)

		Power rating				
Speed		110%	100%	75%	50%	25%
1500	Litres	15.9	14.6	10.8	7.56	4.2
	SFC	216.8	217.7	215.4	224	252

Induction system

Maximum air intake restriction
 Clean filter 5 kPa
 Dirty filter 8 kPa
 Air filter type Dry

Electrical system

Type	Negative ground
Alternator voltage	12 volts
Alternator output	65 amps
Starter motor voltage	12 volts
Starter motor power	3 kW
Number of teeth on flywheel	126
Pull in current of starter motor solenoid	60 amps
Hold in current of starter motor solenoid	15 amps
Engine stop solenoid	12 volts
Stop solenoid (minimum):	
Pull in current	10 amps
Hold in current	10 amps

Cold start recommendations

Minimum cranking speed 105 rpm

Starter specification

Starter motor type	Min. starting temp. °C (°F)	Lubricating oil viscosity SAE / battery type - values in CCA			
		15W/40	10W/40	5W/40	5W/30
12 volt 3.0 kW	-10 (14)	1 x 660			
	-15 (5)*		1 x 660		
	-20 (-4)*			1 x 660	
	-25 (-13)*				2 x 570

* Start aid required

Note: CCA - Cold Cracking Amps to SAEJ537.

Note: Battery capacity is defined by the 20 hour rate.

Note: If a change to a low viscosity oil is made, the cranking torque necessary at lower ambient temperatures is much reduced. The starting equipment has been selected to take advantage of this. It is important to change the appropriate multigrade oil in anticipation of operating in low ambient temperatures.

Note: Breakaway current is dependent on battery capacity available. Cables should be capable of handling the transient current which may be up to double the steady cranking current.

Recommended SAE viscosity

A single or multigrade oil must be used which conforms to API-CG4 / CH4, see illustration below.

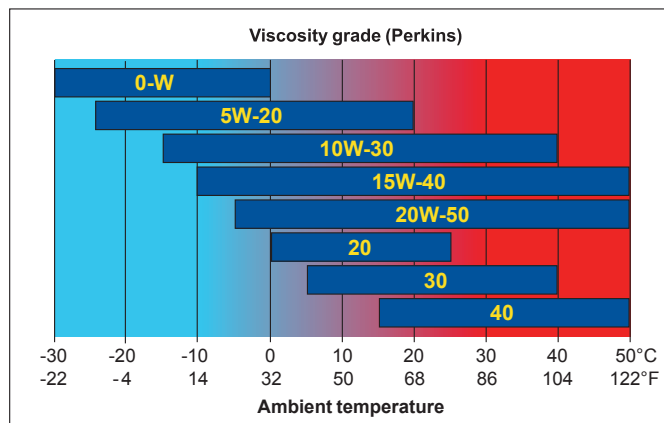

Mountings

Maximum static bending moment at rear face of block...791 Nm (583 lb/ft)

Load acceptance

Initial load application: When engine reaches rated speed (15 seconds maximum after engine starts to crank)			
Descriptor	Units	1500 rpm	1800 rpm
Prime power	%	85	95
Load	kWm (kWe)	46.8 (40.7)	60.1 (51.7)
Transient frequency deviation	%	< -10	< -10
Frequency recovery	Seconds	< 1	< 1

The above complies with requirements of Classification 3 & 4 of ISO 8528 - 12 and G2 operating limits stated in ISO 8528 - 5.

The above figures were obtained under the test conditions as follows:

Engine block temperature	15 °C
Alternator efficiency89%
Minimum ambient temperature	15 °C

Isochronous governing

Typical alternator inertia 0.496 kgm²

All tests were conducted using an engine installed and serviced to Perkins Engine Company Limited recommendations.

The information given in this document is for guidance only.

1103A-33TG2 - Left side view

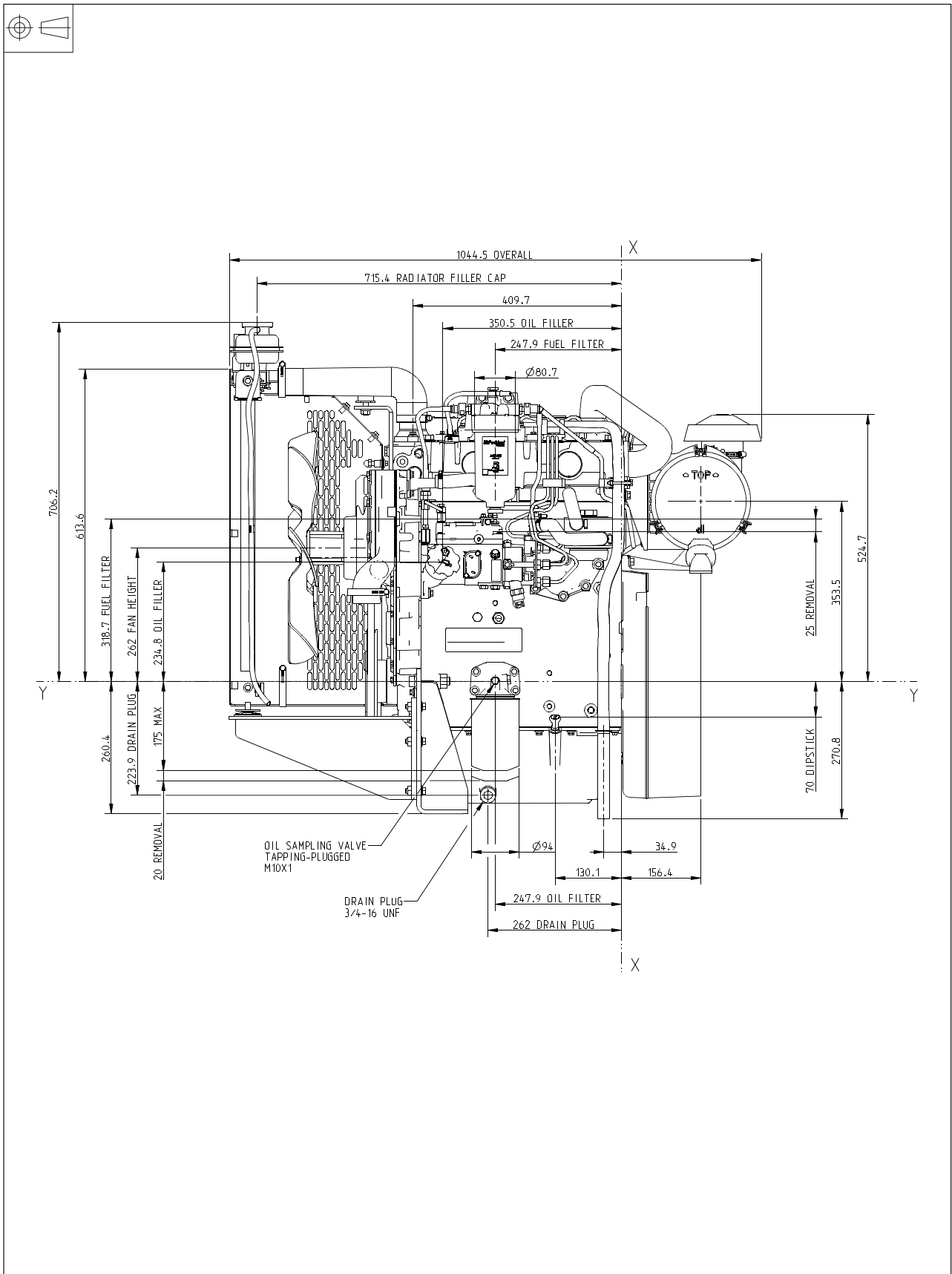

1103A-33TG2 - Front side view

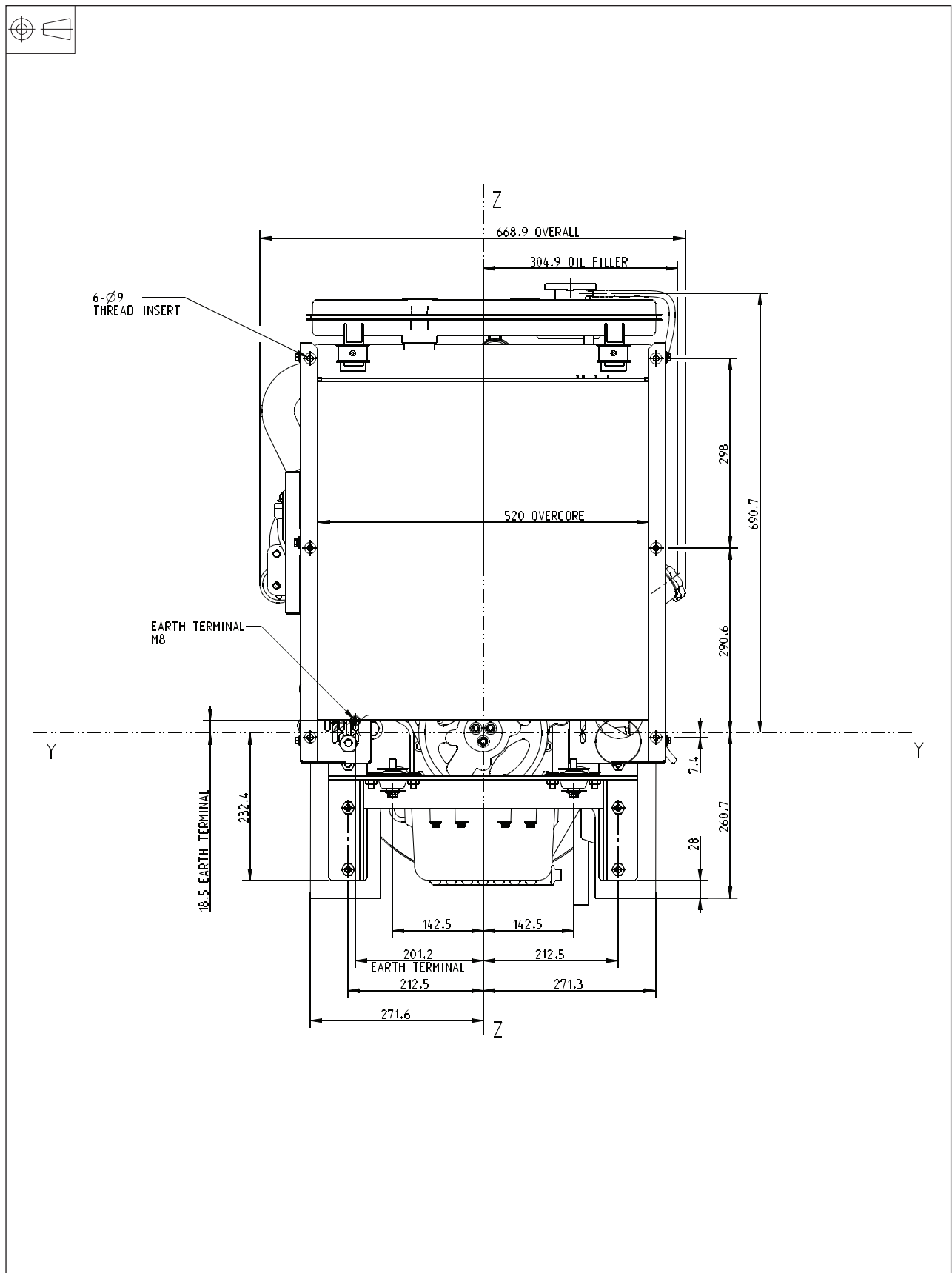

1103A-33TG2 - Right side view

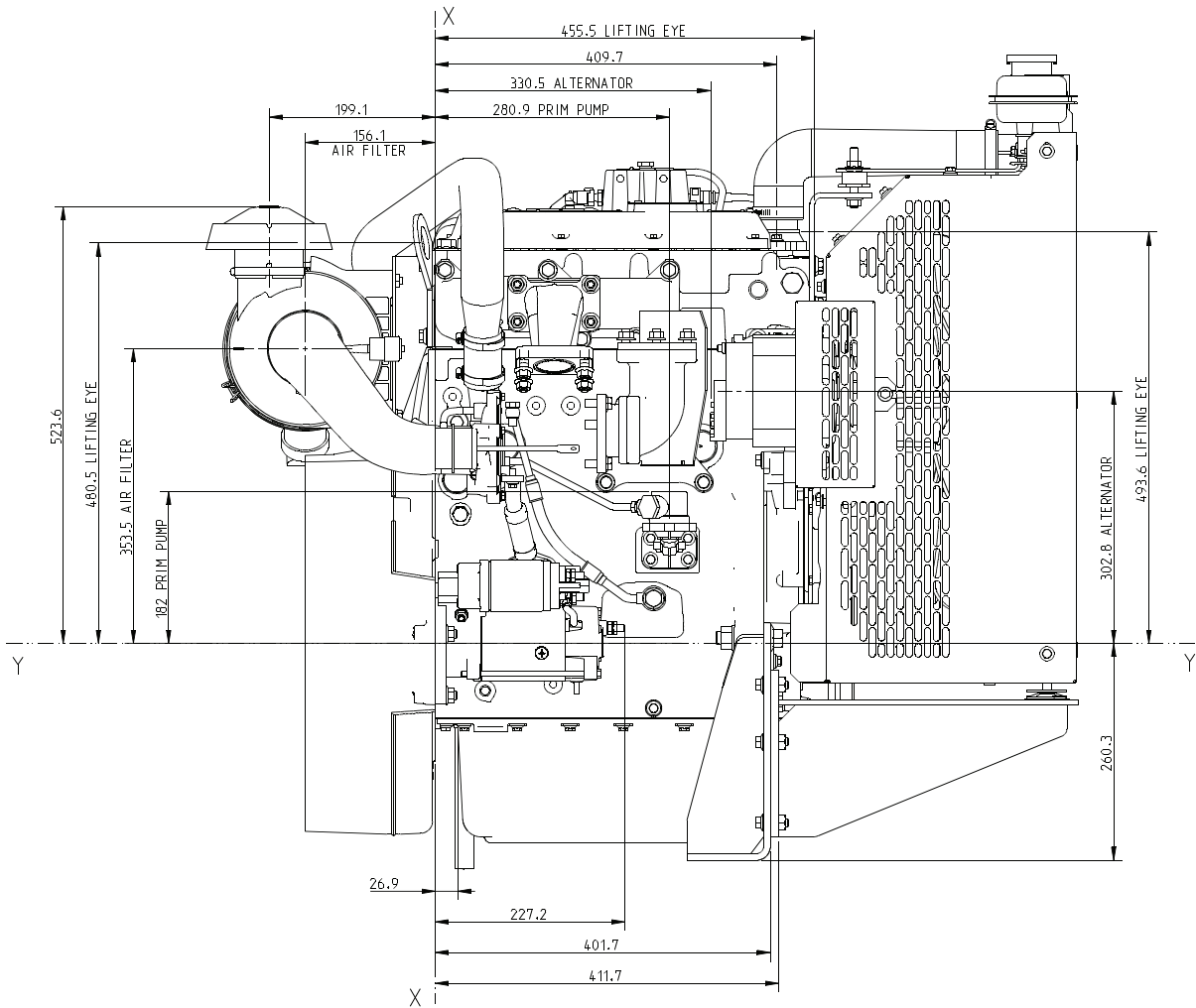

1103A-33TG2 - Rear side view

